

Reno

SYSTEM SERIES



High Efficiency System Boilers

Installation, Maintenance & Service Instructions

Natural Gas G20:

HE16S - GC No: 41-416-05
from Serial No. 76000247

HE25S - GC No: 41-416-02
from Serial No. 69000778

HE31S - GC No: 41-416-04
from Serial No. 77000182

Propane G31 Variants:

HE16SP - GC No: 41-416-09
from Serial No. 82000102

HE25SP - GC No: 41-416-12
from Serial No. 72000112

HE31SP - GC No: 41-416-08
from Serial No. 84000101



The Johnson & Starley Reno range has an energy rating A on a scale of A to G.

For more information see www.boilers.org.uk

This is a certification mark.

CONTENTS

Section	Description	Page
1.	Important Information	3
2.	Appliance Description	3
3.	Fitting	10
4.	Commissioning and Handover	21
5.	Servicing Schedule	22
6.	Fault Finding & Repair	24
7.	Short Spare Parts List	33



THE BENCHMARK SCHEME

Benchmark places responsibilities on both manufacturers and installers. The purpose is to ensure that customers are provided with the correct equipment for their needs, that it is installed, commissioned and serviced in accordance with the manufacturer's instructions by competent persons and that it meets the requirements of the appropriate Building Regulations. The Benchmark Checklist can be used to demonstrate compliance with Building Regulations and should be provided to the customer for future reference.

Installers are required to carry out installation, commissioning and servicing work in accordance with the Benchmark Code of Practice which is available from the Heating and Hotwater Industry Council who manage and promote the Scheme. Visit www.centralheating.co.uk for more information.



Johnson & Starley Ltd, Rhosili Road, Brackmills, Northampton, NN4 7LZ
Tel: 01604 762881 Fax: 01604 767408 Sales Fax: 01604 764879
www.johnsonandstarley.co.uk

Johnson & Starley reserves the right to change specification without prior notice.

1. IMPORTANT INFORMATION

IT IS A STATUTORY REQUIREMENT THAT ALL GAS APPLIANCES ARE INSTALLED BY COMPETENT PERSONS, (i.e. GAS SAFE REGISTERED INSTALLERS. GAS SAFE MEMBERSHIP ENQUIRIES - 0800 408 5500) IN ACCORDANCE WITH THE GAS SAFETY (INSTALLATION AND USE) REGULATIONS (CURRENT EDITION). FAILURE TO COMPLY WITH THESE REGULATIONS MAY LEAD TO PROSECUTION.

This appliance has been Tested and Certified in order to meet the necessary European Directives and comply with the latest Building Regulations, including the efficiency requirements of the SEDBUK scheme.

Efficiency of Hot Water Boilers Directive 92/42/EEC

Gas Appliance Directive 90/396/EEC

Low Voltage Directive 93/68/EEC

Electromagnetic Compatibility Directive 92/31/EEC

No modifications to this appliance should be done unless they are fully approved by the manufacturer.

The installation of this appliance must be carried out by a competent person and must be in accordance with the current rules in force at the time of installation, in the country of destination.

The manufacturers instructions supplied must not be taken as overriding any statutory requirements.

The weight of this appliance exceeds that recommended for a one-man lift. It will therefore be necessary to gain assistance at times during the installation procedure.

It should be noted that this appliance may contain sharp edges. In order to prevent injury, care MUST be taken when handling the appliance! We advise the engineer to wear suitable P.P.E.

A two year manufacturers warranty applies to this appliance.

GAS LEAKS: DO NOT OPERATE ANY ELECTRICAL SWITCHES, OR USE A NAKED FLAME. TURN OFF THE GAS SUPPLY. VENTILATE THE AREA BY OPENING DOORS AND WINDOWS. CALL THE NATIONAL GAS EMERGENCY SERVICE ON 0800 111 999.

2. APPLIANCE DESCRIPTION

The appliance is a high efficiency system boiler that is designed to provide the user with both central heating and domestic hot water. Its design is such that it is room sealed, taking combustion air from outside and expelling the products of combustion to the outside again. The heat exchanger is constructed of stainless steel, which is corrosion free. Flueing options ensure that the appliance can be installed in many locations within a building and a schematic diagram (fig. 2-4) shows the water flow through the boiler.

The appliance is controlled by fully featured microprocessor based electronics that monitor each of the operational procedures. An LCD display indicates the operational state of the appliance which illuminates for a short period when the user control is operated. This starts with the full sequence automatic ignition and continues with monitoring the demand requirements of either the central heating or the domestic hot water.

Should any fault occur the appliance will be shutdown to a safe condition with the fault code being displayed on the LCD panel.

2.1 Appliance Safety Devices

Heating System Pressure Relief Valve

The appliance incorporates a pressure relief valve to protect the sealed water system from being over pressurised. The discharge from this must be piped away to a safe place in accordance with the building regulations. Should there be a discharge of water/steam from this device, the appliance should be switched off and a service engineer or the installer called.

Frost Protection

The microprocessor based controls within the appliance monitor the water temperature in order to protect from freezing. To ensure that this function is active the main switch on the appliance should be left on and the gas supply also left on.

This does not protect remote areas of the heating system, which should be protected by other means (e.g. an independent frost thermostat that is linked back to the appliance).

Overheating Safety

There are a number of overheat safety devices on the appliance. Should any of these operate (see the fault codes table in section 6.1) you should call a service engineer or the installer

Electrical Supply Failure

In the event of electrical voltage supply failure, the appliance will stop operating but remain in a safe condition. When the electrical supply is resumed, the appliance will start from its safe off condition and continue to operate in the normal manner under the control of the system components. Should the appliance fail to resume, press the RESET button to allow the safety control to be reset. Normal operation should then continue.

2.2 Technical Data

	HE16S	HE25S	HE31S
Maximum Lift Weight	33.0 Kg	33.0 Kg	34.0
Gas Connection	15 mm copper		
Heating flow and return	22 mm copper		
Safety valve discharge	15 mm copper		
Condensate Drain	3/4 inch plastic overflow pipe		
Maximum heating system water content using fitted expansion vessel, pressurised at 1 bar	73 litres		
Electrical supply	230V		
Electrical rating	145W		
IP classification	IP 40		
External fuse rating	3 A		
Expansion vessel capacity	8 litres		
Expansion vessel initial charge pressure	1.0 bar		
Heating system minimum pressure	0.7 bar		
Ball valves are fitted in water and gas connections			
For larger systems use an additional expansion vessel			

**Table 2-1
General Data**

		Nat Gas G20						LPG G31					
		16S	25S	31S	16S	25S	31S	16S	25S	31S	16S	25S	31S
		Maximum			Minimum			Maximum			Minimum		
Burner CO2 (%)	Case off	9.5*	9.3*	9.5*	8.5**	8.4**	8.5**	10.1*	10.2*	10.2*	9.2**	9.4**	9.2**
	Case on	9.8*	9.5*	9.8*	8.8 **	8.6**	8.8**	10.3*	10.4*	10.5*	9.4**	9.6**	9.5**
		* = +0.5						** = Ref Only					
Offset (Pascal)		-3.0 (Minus three)**											

**Table 2-2
Performance Data**

Table 2-3
Performance Data (Central Heating)

			Nat Gas G20					
			Maximum			Minimum		
CH Input Q			16S	25S	31S	16S	25S	31S
	Net	kW	16.3	25.5	30.7	3.81	7.14	9.18
	Gross	kW	18.1	28.3	34.0	4.23	7.92	10.1
Gas Consumption		m ³ /h	1.7	2.6	3.16	0.40	0.74	0.85
CH Output P	Non Condensing	kW	16.0	25.0	30.0	4.08	7.0	9.0
	Condensing	kW	17.8	27.85	32.6	3.75	7.76	9.8
SEASONAL EFFICIENCY (SEDBUK)			'A'					
NOX CLASSIFICATION			Class 5					

			LPG G31					
			Maximum			Minimum		
CH Input Qm			16S	25S	31S	16S	25S	31S
	Net	kW	16.3	26.06	30.7	3.81	7.29	1.18
	Gross	kW	17.7	28.3	33.3	4.14	7.92	9.97
Gas Consumption		m ³ /h	0.67	1.06	1.25	0.16	0.30	0.38
CH Output P	Non Condensing	kW	16.0	25.0	30.0	3.75	7.0	9.0
	Condensing	kW	17.2	27.85	32.6	4.02	7.76	9.8
SEASONAL EFFICIENCY (SEDBUK)			'A'					
NOX CLASSIFICATION			Class 5					

Please Note:

Natural Gas (G20) consumption is calculated using gross CV of 38.7 MJ/m³ or 34.9 MJ/m³ net.

LPG (G31) consumption is calculated using gross CV of 95.6 MJ/m³ or 88.0 MJ/m³ net.

2.3 Dimensions and Clearances:

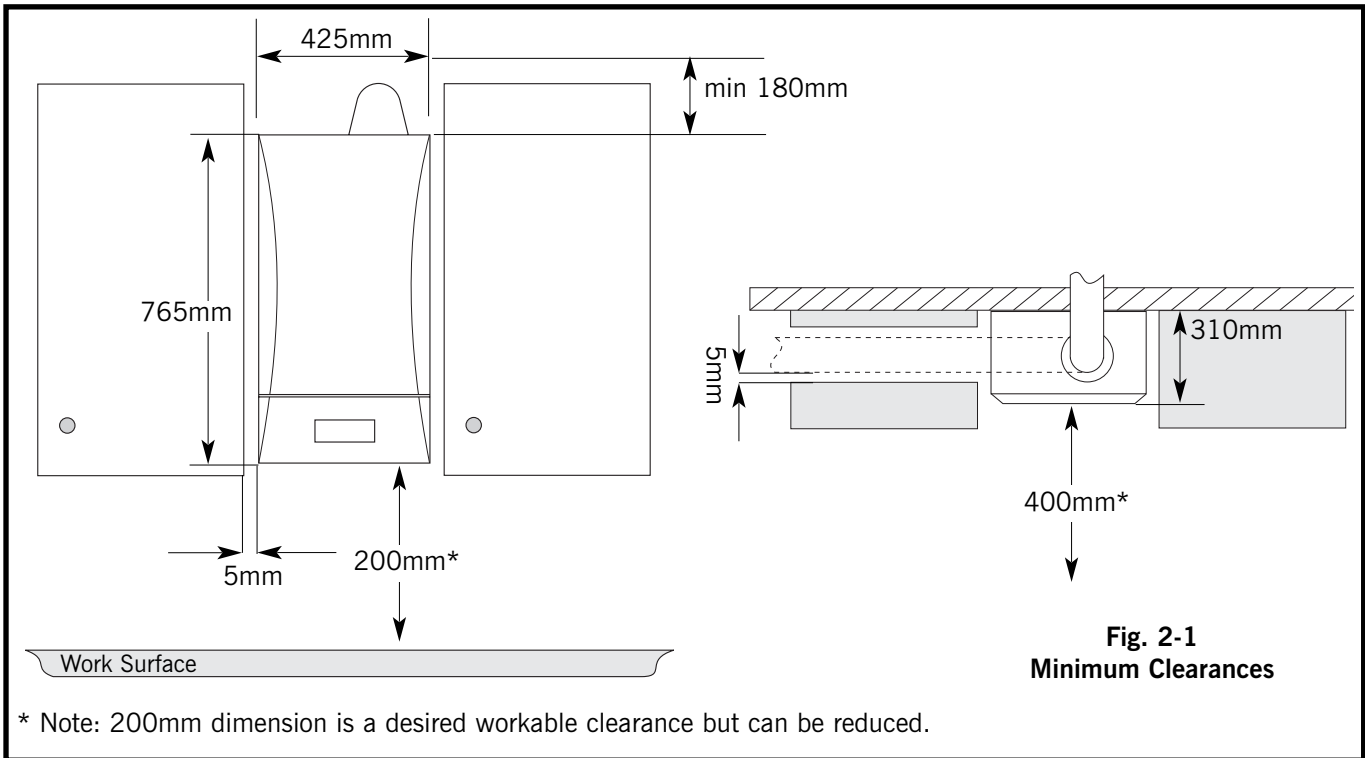

It is recommended that where the appliance is located in a kitchen, or next to other combustible materials, a gap of 5mm be left on either side and where the flue run is through a void in kitchen units, again a minimum gap of 5mm should be left.

***NOTE** - These are recommended clearances when servicing the appliance.

2.4 General Information

Appliance Classification

The appliance is certified as a type C13 C33 C53. As such it can only be installed with the flue components specified within this document. The flue types are:

- Horizontal and vertical balanced flue using concentric ducts.
- Air entry and flue exit in zones of different pressure using twin (separate) flue and air ducts.

Gas Categories:

The appliance is certified as a CAT II 2H 3P appliance. This allows conversion between Natural gas (G20) and LPG (G31). Their supply pressures are 20 mbar and 37 mbar respectively.

For natural gas to LPG conversion, kit number NG30 (complete with instructions) is available.

For LPG to natural gas conversion, kit number LPG30 (complete with instructions) is available.

Statutory Requirements:

The appliance must be installed in accordance with the current editions of:

- Building Standards (Scotland)(Consolidation) Regulations.
- Building Regulations
- Gas Safety (Installation and Use) Regulations (as amended)
- BS 7671 Institute of Electrical Engineers (I.E.E) Wiring Regulations
- BS 6891 Installation of Low Pressure Gas Pipework of up to 28 mm (R1) in domestic premises (2nd family gases).
- BS 5440 Pt.1 (Flues for Gas Appliances)
- BS 5440 Pt.2 (Air Supply for Gas Appliances)
- Model and Local Authority Byelaws
- BS 5546 Installation of Domestic Hot Water Supplies.

Gas Supply:

The gas installation must be completed in accordance with the relevant standards (BS 6891).

The supply must be capable of providing a steady inlet working pressure to the appliance of 20 mbar at a rate of 1.7 m³/h (HE16S) 2.7 (HE 25S) and 3.16 m³/h (HE31S) (Calculated with a Gas CV of 38.7MJ/m³)

The installation must be tested for gas soundness using suitable methods. The pipework should also be purged of air in accordance with the above standard.

Additional Plumbing Kit for Top Outlet CH Pipes:

Should the installation require the heating flow and return pipes to exit the appliance upwards, provision has been made to allow the installation of two pipes (flow & return) to pass up the rear left hand side. These pipes can be made on site. Pre-fabricated pipes (kit number VPK30) are available direct from Johnson & Starley if required.

Additional Control Options:

Should an outside temperature compensation system be required, Opentherm kits are available direct from Johnson & Starley. (Part No.1000-0019720)

2.5 Appliance Location:

The appliance is not suitable for external installation unless it is protected from the elements by a suitable enclosure. The enclosure must provide the required clearances for installation, servicing and maintenance as well as the correct level of ventilation. The selected position should allow for a suitable flue system to be installed.

When installed in a timber frame building guidance should be taken from the gas industry publication IGE/UP-7 (Guide for Gas Installations in Timber Frame Housing).

BS 6798 gives details of the essential features for a compartment or cupboard where a gas appliance is to be installed. An existing cupboard may require modification.

If the appliance is installed in a room containing a bath or shower it is important to locate the electrical switch in a position where it cannot be touched by anyone using the bath or shower. The current IEE Wiring Regulations (BS 7671) for England and the electrical provision of the Building Regulations for Scotland gives details.

Room ventilation for the appliance is not necessary as the appliance draws its combustion air from outside of the building and cupboard or compartment ventilation is not necessary providing that the minimum clearances are maintained. However, reference should be made to BS5440 Pt.2

2.6 Heating System Requirements:

This appliance incorporates all the necessary components to allow it to be connected to a sealed central heating system. A typical system is shown at fig. 2.2 which incorporates radiators, an automatic by-pass valve and a drain facility that must be provided at the lowest point in the system to allow complete drain down. The installation should be designed to operate with a flow temperature of up to 90 deg.C.

Expansion Vessel: The integral expansion vessel is pre-charged to a pressure of between 0.5 and 1.0 bar. This should be checked before the water system is filled. Details below show the water system volume that is acceptable for this vessel. If the system water volume is larger then an additional vessel must be fitted to the system. BS 5449 and BS 6798 give further details regarding expansion vessel sizing and sealed systems. See table 3-2

Pressure Gauge: The appliance has two components that monitor pressure. Firstly there is a mechanical pressure gauge on the plumbing jig, this allows the heating system to be pre-plumbed and filled with a visual check on the pressure. The second is an electronic device used by the microprocessor control to monitor the system pressure and block the heat input, should there be a lack of pressure.

LCD Display: When the electrical supply is connected, the liquid crystal display indicates the system water pressure. This pressure is also monitored by the microprocessor controls.

Pressure Relief Valve: The pressure relief valve protects the system from over pressurisation. It is set to be fully open at 3 bar, however it will start to open at approximately 2.7 bar. It should not be used to flush the system.

Filling: Provision for filling the CH system must be made and three methods are shown in fig. 2.3 Connections to the mains supply must not be permanent, even through a non-return valve. Fittings used for connection to potable water must comply with the water supply (water fittings) regulations 1999 Section G24.1 and G24.2.

Pipework Sizing: In order to keep the noise of the system to a minimum, the velocity of water should be kept below 1.5 m/s and it should be noted that the appliance is designed to operate with a temperature differential of 20°C between flow and return. The maximum flow rate is 0.19 kg/s (HE16S) 0.3 kg/s (HE25S) and 0.38 kg/s (HE31S) which through a 22mm pipe gives a velocity of 0.75 m/s (HE16S) 1.00 m/s. (HE25S) and 1.25 m/s (HE31S) Therefore, the recommended minimum pipe size for the main carcass is 22mm.

Water Treatment: It is important that the system is flushed thoroughly before the appliance is left to operate (as recommended in BS 7593) in order to maintain an efficiently operating heating system. For replacement installations, the system MUST be flushed with the old boiler in situ, in order to prevent the Reno becoming a trap for system debris. Once the system has been flushed, an inhibitor (suitable for stainless steel heat exchangers should be added. Appropriate inhibitors are available, for example Sentinel and Fernox.

Failure to carry out the above procedure will invalidate the guarantee!

NOTE: Water supplied from a water softener MUST NOT be used unless a specially formulated corrosion inhibitor is added (see BS 6798)

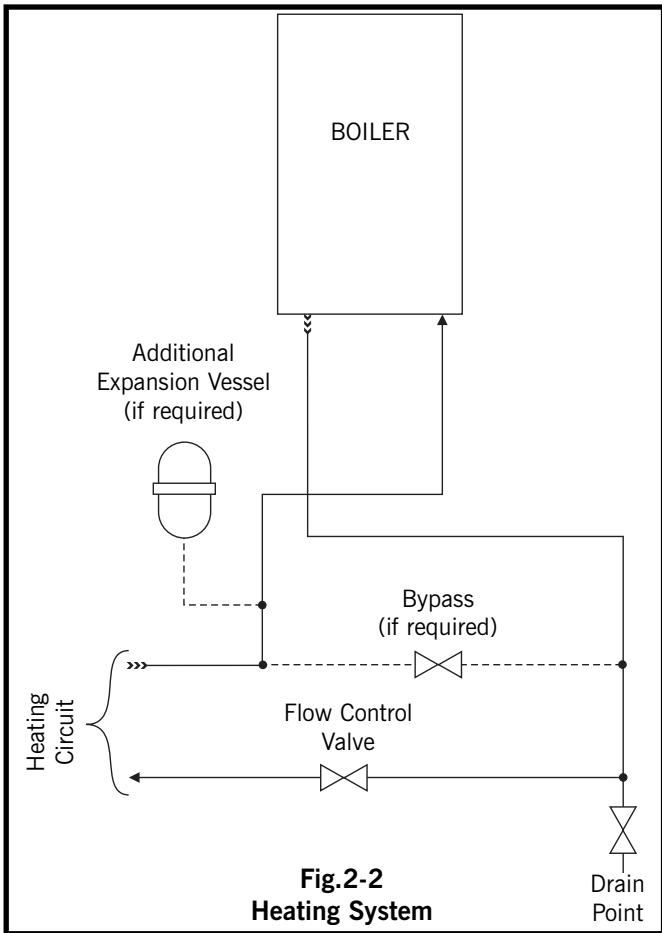

Controls: As a minimum it is recommended that a 2 channel timer and room thermostat is installed to control the appliance. Thermostatic radiator valves may be fitted to the system but must not be fitted in the room where the room thermostat is fitted. There must be at least one radiator installed with lock shield valves that should not be closed. Further guidance can be obtained from the Domestic Heating and Hot Water Guide to the building regulations and GPG 302

NOTE: a differential pressure bypass valve MUST be installed to maintain the following minimum flow rates:

12 L/min - HE16S

18 L/min - HE25S

23 L/min - HE31S

(20° differential at maximum heat input).

2.7 Domestic Hot Water System Requirements:

Domestic hot water circuits and their components must be in accordance with the relevant standards and water supply regulations. Further guidance and recommendations can be found in the building regulations G17 to 24 and R17 to 24.

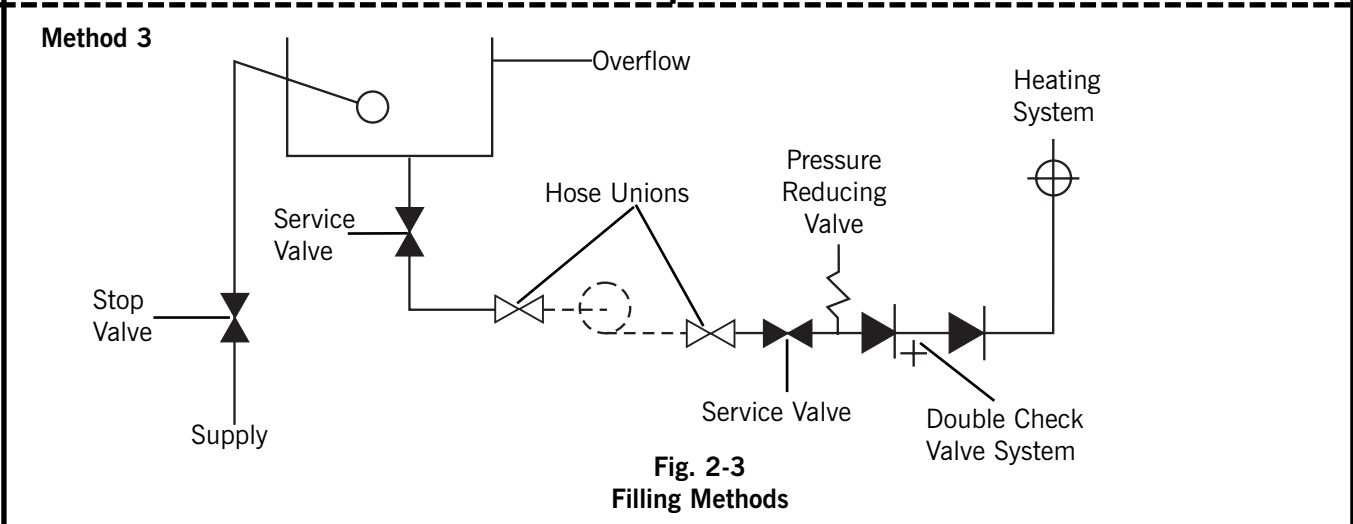
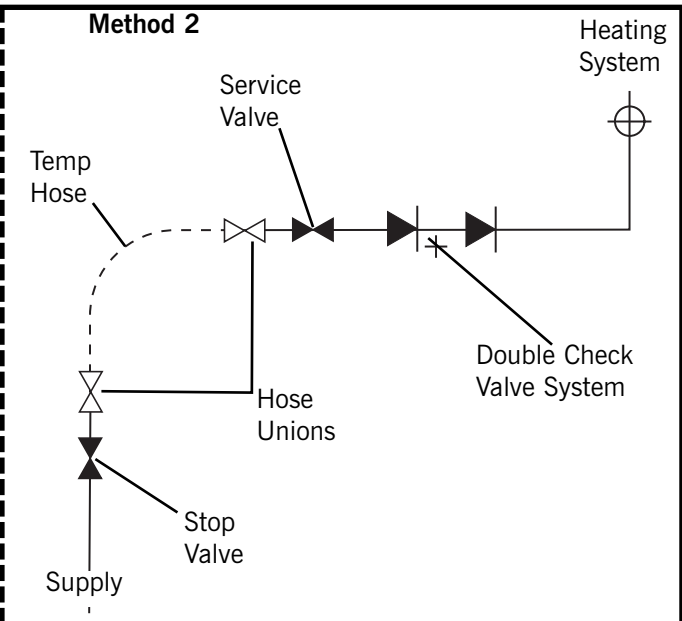
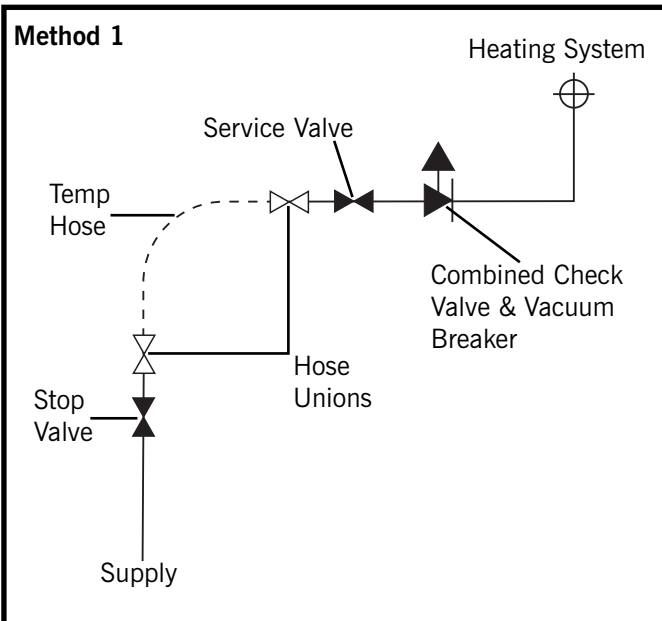

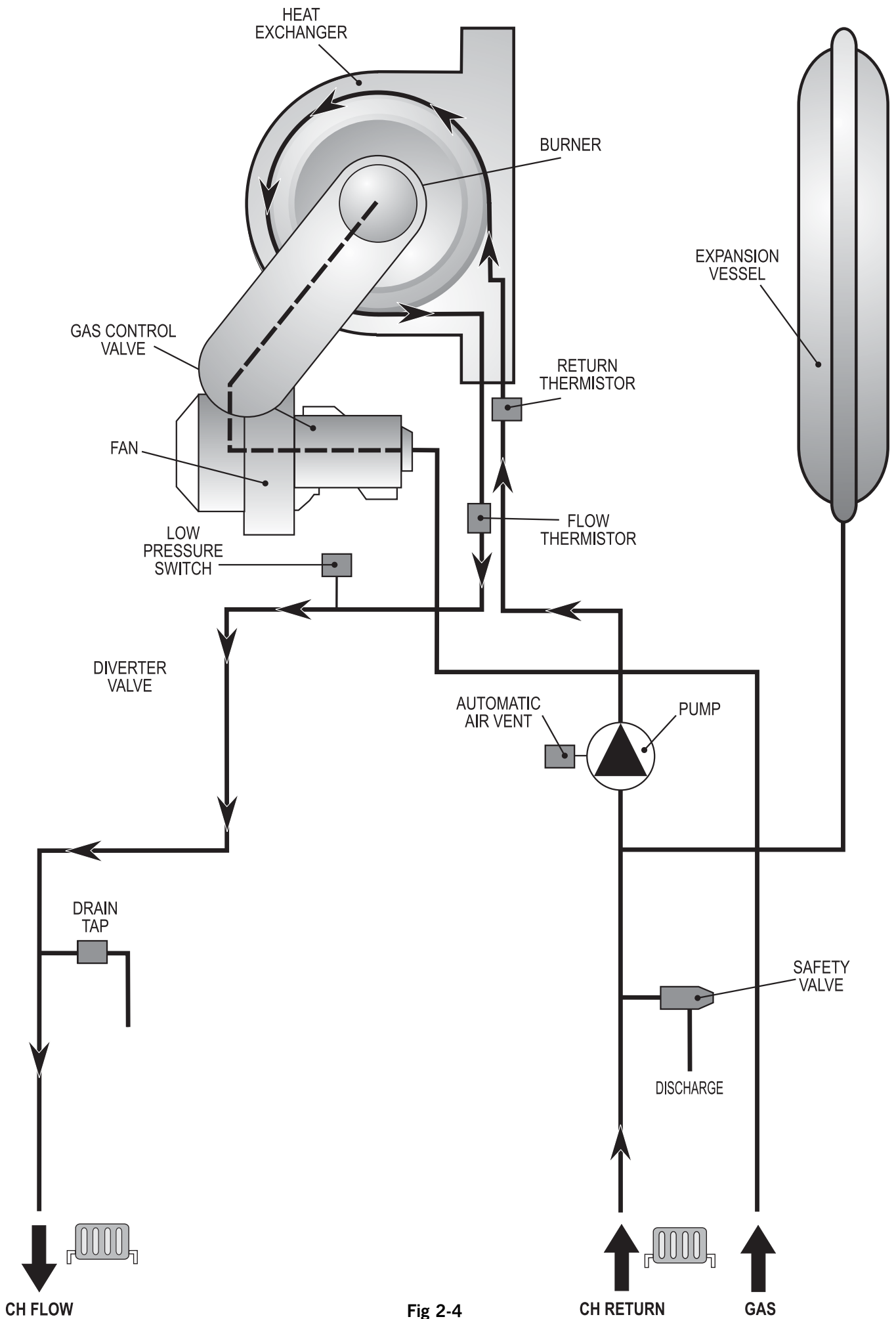

Fig 2-4
Schematic Diagram
(Waterflow)

3. FITTING

3.1 Unpacking the Appliance:

The appliance is supplied packaged complete in one carton

Caution: this appliance exceeds the recommended weight for a one-man lift as detailed in the Manual Handling Operations, 1992 Regulations.

NB: if the pipework is to run behind the boiler and into the ceiling, you will require J & S kit number SOK1 which will provide a void at the rear of the boiler.

3.2 Preparing the Wall/Fitting Wall Plate

Ensuring the wall is flat, unpack the wall template from its protective sleeve and place it on the wall giving consideration to: the flue position; water/gas connection positions and clearances. Use the plumb line on the template to ensure it is square! Mark the positions on the wall of the flue and the fixing points. Using a 105 mm core drill make the hole through the wall in the correct place. Installations that are made from within the building only will require a 125 mm diameter hole in order to fit the flue system.

Using a 7mm bit, drill a total of 4 fixing holes for the wall plate and insert the rawplugs. Remove the template.

3.3 Wall Plate:

Fix the wall plate to the wall, ensuring it is level and secure it with the screws provided.

Lift the appliance onto the wall plate and locate the unit on the two lugs at the top. The boiler then drops into place and needs no further fixing.

Figure 3.1

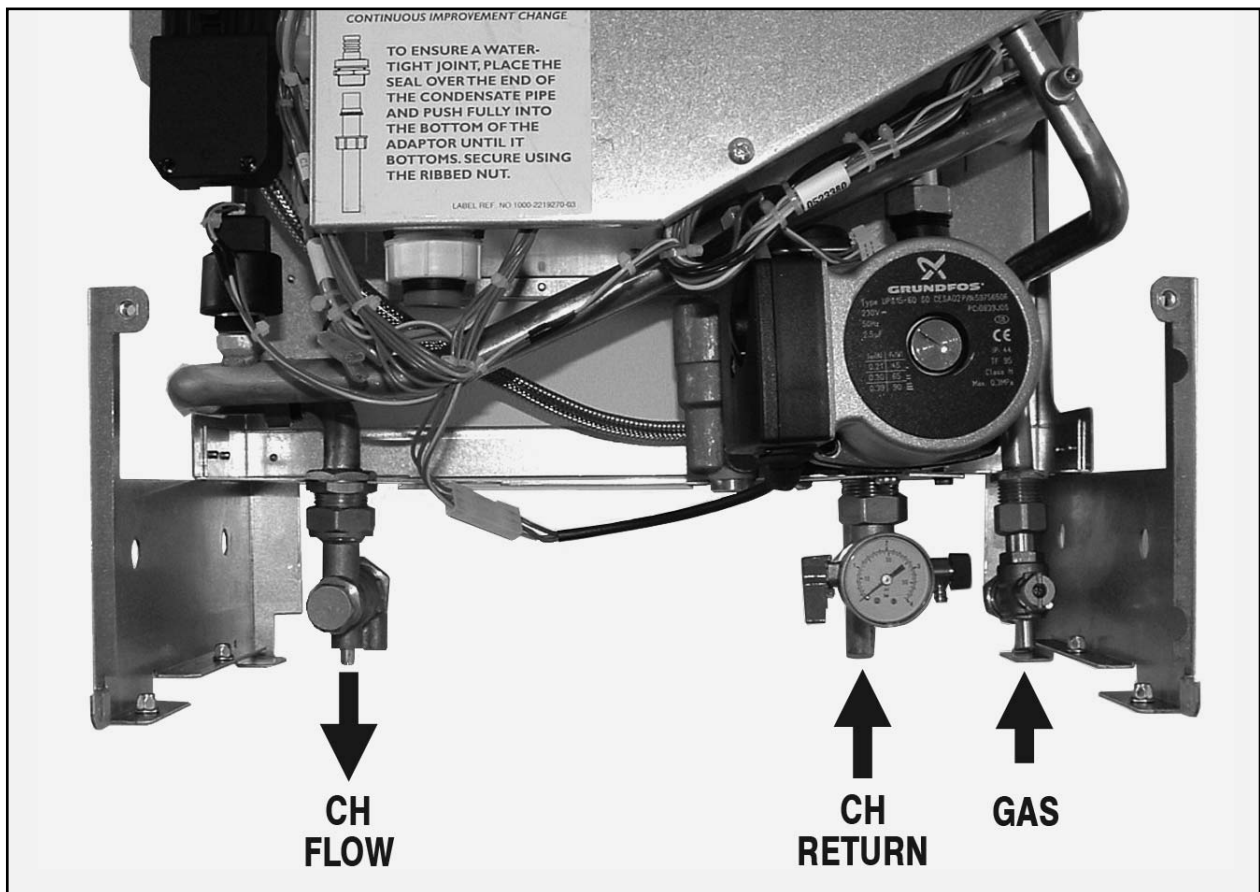

CARTON CONTENTS

- System Boiler
- Wall Plate
- Boiler Kit
- Filling Loop Pack
- Paper Template
- Rawplug/Screw Pack
- Installation Instructions (inc. Benchmark Logbook) & User Guide.
- Guarantee Card

Table. 3-1

3.4 Fitting the Boiler Kit:

Ensure the gas and water connections are in correct alignment. (see Figure 3.1) Connect the gas and water swivel nut joints. The two remaining connections must now be made. These are the condensate drain and the pressure relief outlet.

Please note the gas pipe uses the blue washer.

It is acceptable to fit pipes vertically upwards without a Vertical Pipe Kit (VPK-30) provided the correct route is used. It is advisable to fit additional isolation valves at the top of the appliance to allow complete removal of the appliance and its wall plate. Once the heating system and the domestic water connections are complete the system can be filled, checked for soundness and flushed. See COMMISSIONING section.

3.5 Condensate Drain:

The condensate drain utilises plastic 21.5mm push fit or adhesive overflow pipes and fittings. It should be piped to drain, preferably within the building, maintaining a 44mm in 1m fall away from the appliance. If the drain is routed to outside it should be to a drain or soak away. Protection from freezing in cold weather conditions is also advisable.

NOTE:

* External runs exceeding 3 metres the discharge pipe should be increased to 32mm diameter for complete peace of mind.

If the pipework is to run from the boiler into the ceiling, you will require J & S kit number SOK1 which will provide a void at the rear of the boiler.

Typical Condensate Drain Arrangements:

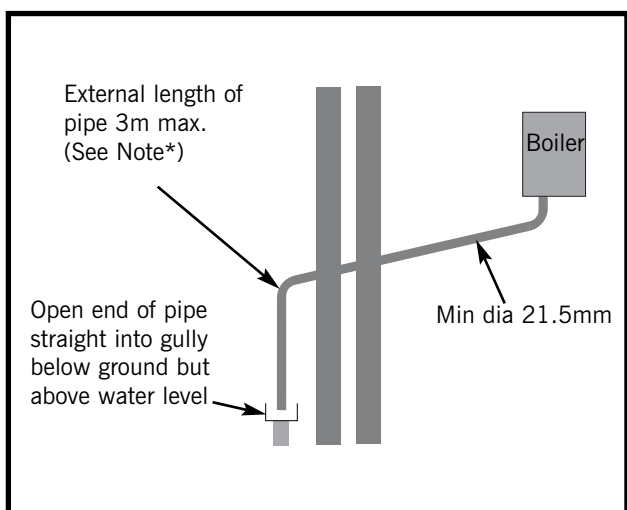
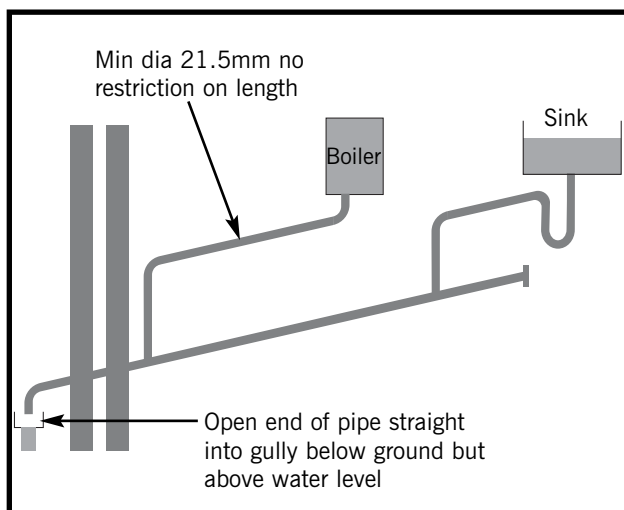
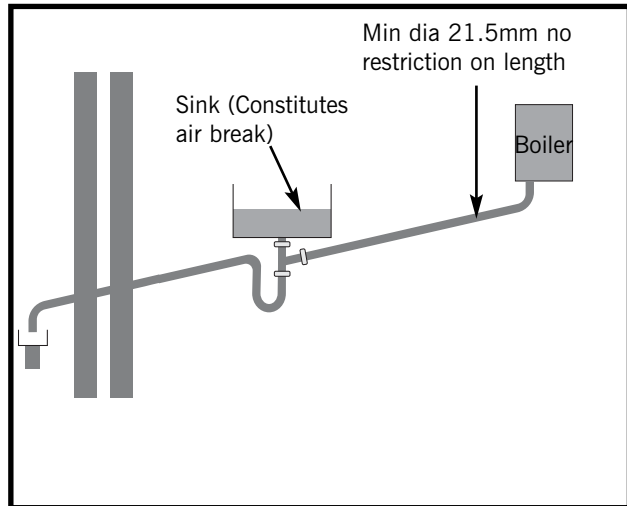
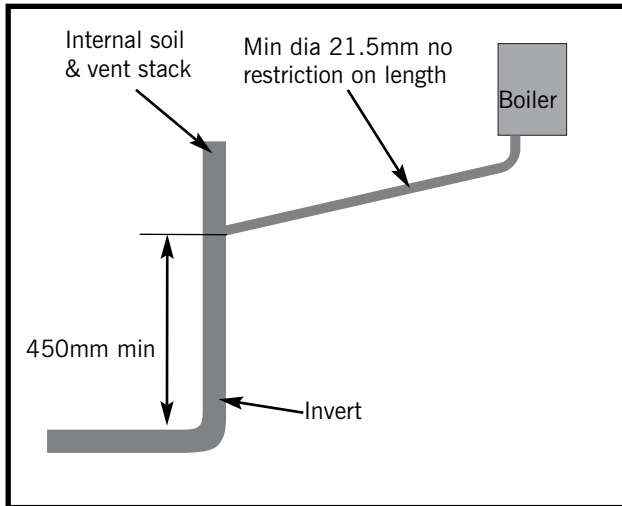

NB the boiler has a built in condensate trap and it MUST be noted that fitting an additional trap to the configurations shown above, may have an adverse effect on the evacuation of condensate from the boiler.

Expansion Vessel Requirements					
Vessel charge and initial system pressure	bar	0.5	0.75	1.0	1.5
Total water content of system using 8 ltr (1.54 gal) capacity expansion vessel supplied with appliance.	ltr	95	84	73	50
For systems having a larger capacity multiply the total system capacity in litres (gallons) by the factor to obtain the total minimum expansion vessel capacity required litres.		0.0833	0.09	0.109	0.156

Table 3-2

3.6 Pressure Relief Outlet:

Using no less than 15 mm diameter copper pipe, the discharge pipe must be extended to a safe place outside the building. The discharge position must be visible, not onto a public access area or above any window or entrance. The pipe must have a continuous fall and discharge to a safe place. It is possible that boiling water and/or steam could be discharged if the safety valve operates.

3.7 Preparing & Installing The Flue Components (100/60 Concentric):

With the appliance fitted to the wall and the gas and water connections complete.

IMPORTANT NOTE: Before carrying out procedure ensure seal has not been dislodged from top of heat exchanger.

Horizontal Flues:

Fit the turret to the appliance with the outlet in the correct direction. Measure the distance between the turret centre line and the outside wall face where the terminal is to be fitted. Using fig. 3.2 assemble and if necessary cut the flue to the correct length and ensure any seals are made correctly. If fitting from outside the building assemble the outer wall-sealing disc onto the flue to its correct position. Insert the flue from outside. Fit the inner wall-sealing disc. Using the clamp arrangement join the flue to the turret, ensuring all the seals are made correctly. The terminal must be installed with the flue outlet at the top. Brackets are provided for extended flues to locate and fix the flue in position should they be necessary.

Vertical Flues.

Flat roof: Measure the distance between the appliance top and the outer surface of the flat roof.

Pitched roof:f Measure the distance between the appliance top and the outer surface of the pitched roof at a point that is central to the flue. Where necessary cut the flue to the correct length, ensuring that seals are made correctly.

It is advisable to assemble the roof flashing onto the vertical terminal and inset this from outside the building. Continue to assemble the remaining flue components and connect to the appliance using the vertical adaptor. Finally make a good seal between the roof and the flashing piece. Brackets are provided to locate and fix the flue in position should they be necessary.

FOR FULL DETAILS OF FLUE COMPONENTS, PLEASE REFER TO ZZ1191

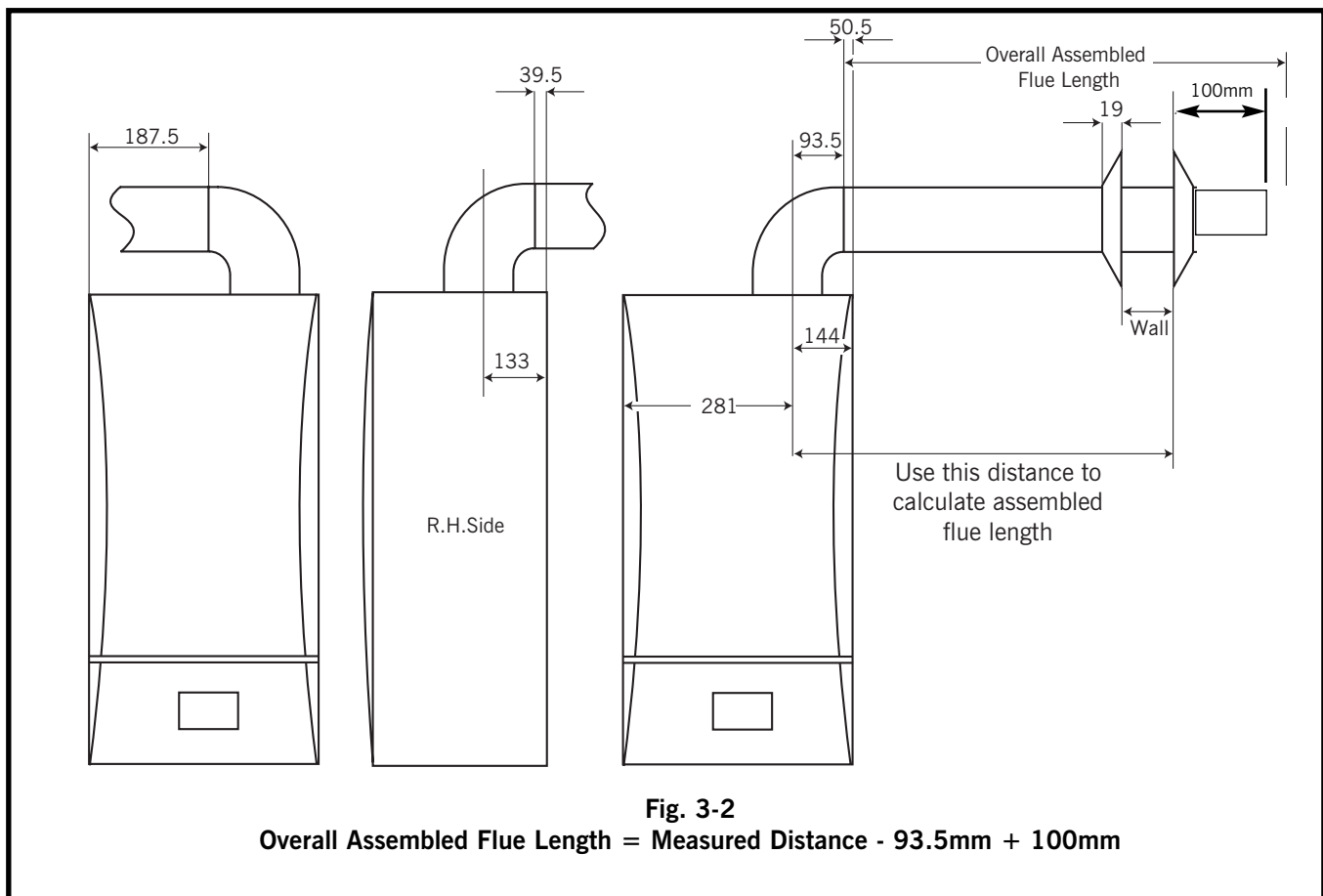

3.8 Flue Terminal Location:

Both the horizontal and vertical terminals must be positioned on the outside of the building and the free passage of air must be available at all times. It is not recommended to position the terminal close to projections especially under a balcony or near to a drainpipe.

Ensure that combustion products cannot enter the building where the heater is installed or near to any other building where doors or windows may be open.

Recommended terminal positions for both horizontal and vertical flues are shown and flue components and installation options are also detailed.

For the installation of a vertical flue either a flat or pitched roof with an angle of between 25° and 50° should be used.

Gas industry publication: "Guide for Gas Installations in Timber Framed Housing DM2", or your local gas region, MUST be consulted when installing the appliance into a timber-framed building.

Where the lowest part of the flue terminal is located less than 2 metres above the ground, a balcony or above a flat roof across which there is access, the terminal MUST be fitted with a guard (part No:1000-0019710) which is available from Johnson & Starley. The distance between the guard and the nearest part of the terminal must not be less than 50 mm.

3.9 Flue Components & Fitting Options (60/100 Concentric Flue System):

The appliance can be purchased with a standard flue kit that includes: horizontal terminal; turret and fitting kit. Details of optional flue components are listed in table 3-5 along with their resistance in Pascals in order that flue length calculations can be made.

Horizontal and vertical concentric flues (60/100 diameter) with balanced terminals and vertical and horizontal flues (twin 80 diameter) with the flue and air inlet terminals terminating at least 500 mm apart may be installed on this appliance.

Note: If a twin duct system is to be used (type C5) then the air inlet and flue outlet must not be on the opposite sides of the building.

If an extended horizontal flue is being used (any flue length longer than the standard kit) it must have a continuous fall back towards the appliance of 2.5°. This ensures that condensate runs back into the appliance from the flue system. Reference should be made to table 3.5 for relevant part numbers

The maximum length of flue permissible is calculated using the component pressure drop and examples are given in table 3-5 which include the maximum lengths at 95% of input.

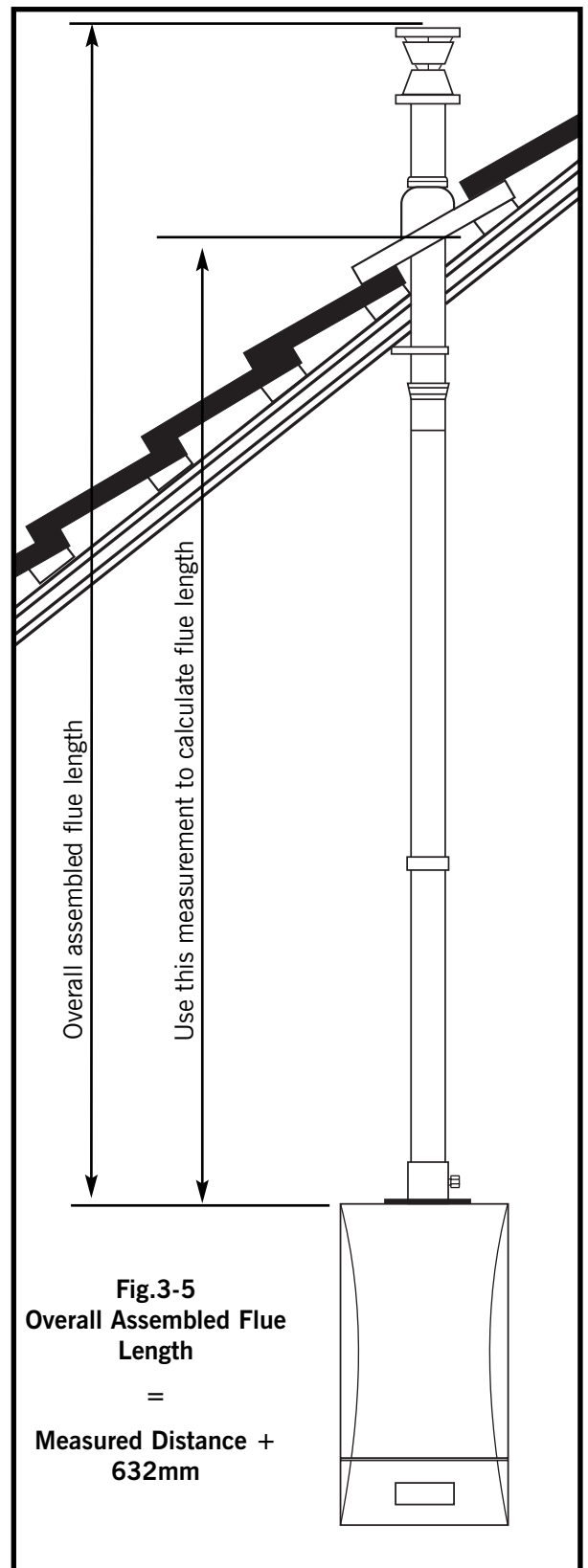

The minimum 60/100 concentric horizontal flue length measured from the centre line of the turret to the outside of the wall is 247mm.

The minimum vertical flue length is 0.7m from the top of the appliance case to the top of the terminal.

The minimum combined 80 twin flue length is 600mm.

Longer flues may be fitted, however the input of the appliance will be reduced accordingly.

Elbows may be fitted within the flue system with a corresponding reduction in overall flue length based on the component pressure drop. Reference should be made to tables 3-3 to 3-5)

It is recommended the terminals are not sited within 2 m of an opening in an adjacent building or within 2m of the boundary facing the terminal if the plume is likely to cause a nuisance to a neighbour, e.g discharging over a walkway or patio.

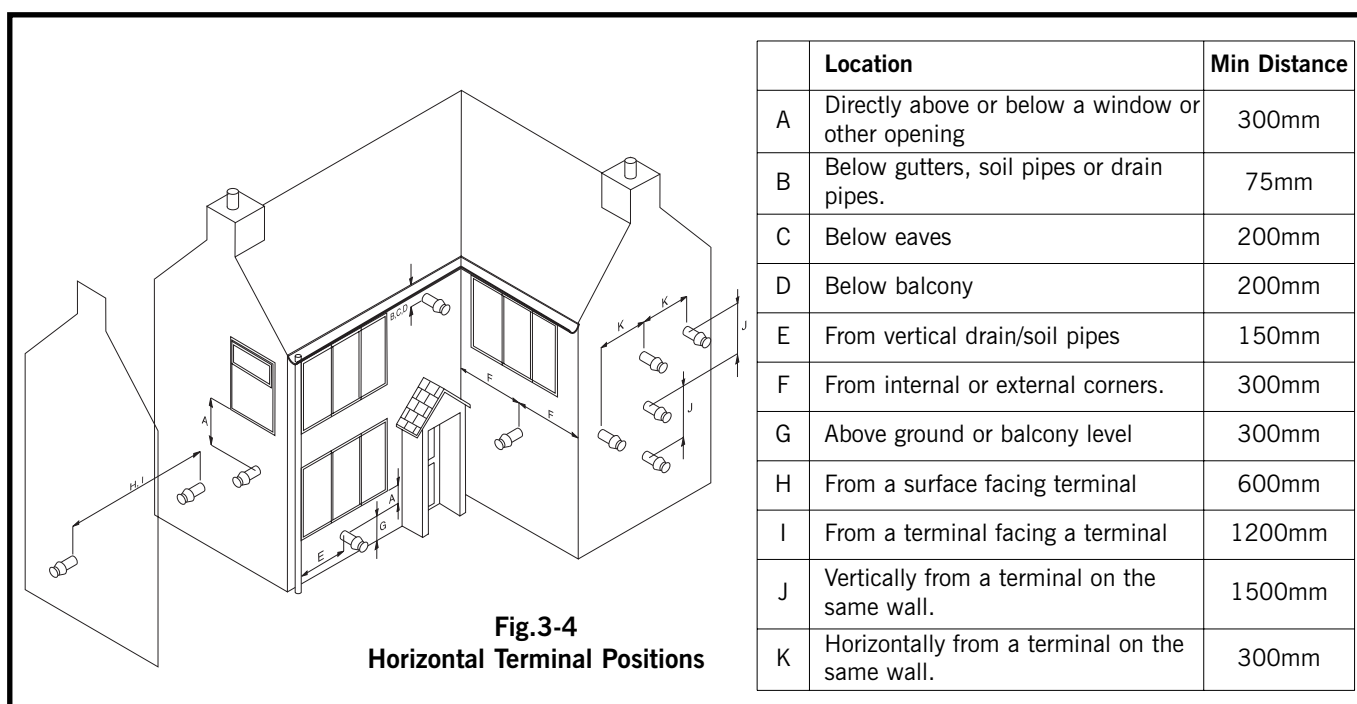
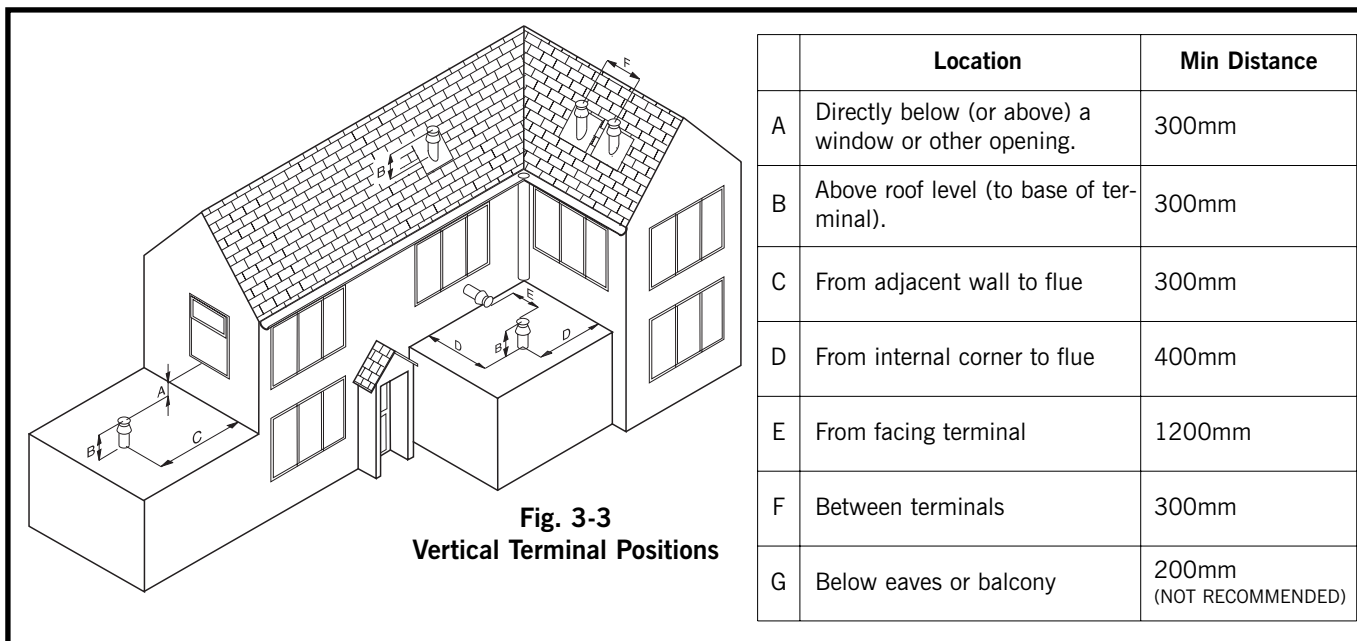

3.10 Plume Terminal Outlets

A flue duct outlet of an appliance should be at least 600mm from the boundary line when facing it and at least 300mm from the boundary line when running parallel to it. (see Fig 3.4a)

NOTE: When the flow of products is at an angle to the boundary, the 600mm dimension may be measured in the direction of the flow, as long as the terminal is not less than 300mm from the boundary.

It is recommended the terminals are not sited within 2 m of an opening in an adjacent building or within 2m of the boundary facing the terminal if the plume is likely to cause a nuisance to a neighbour, e.g discharging over a walkway or patio.

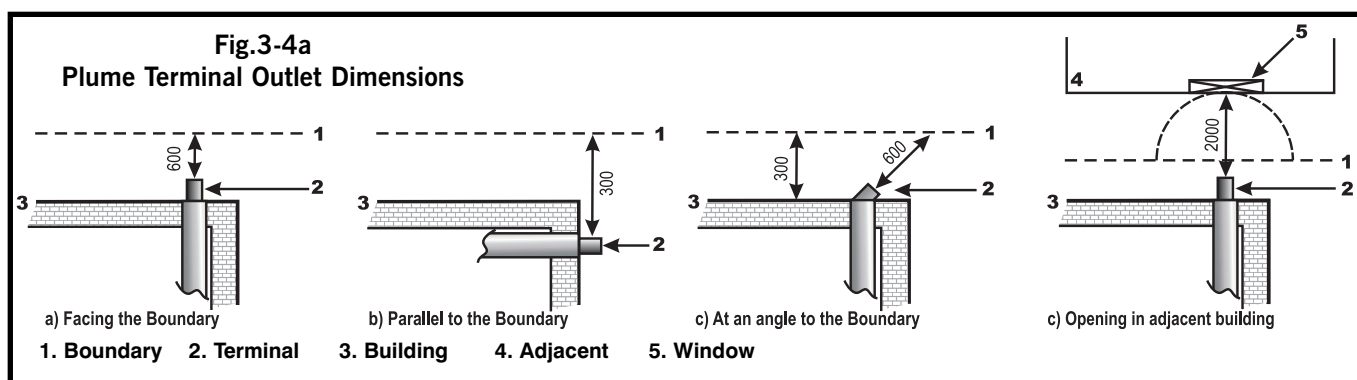

Typical Concentric Flue Configurations

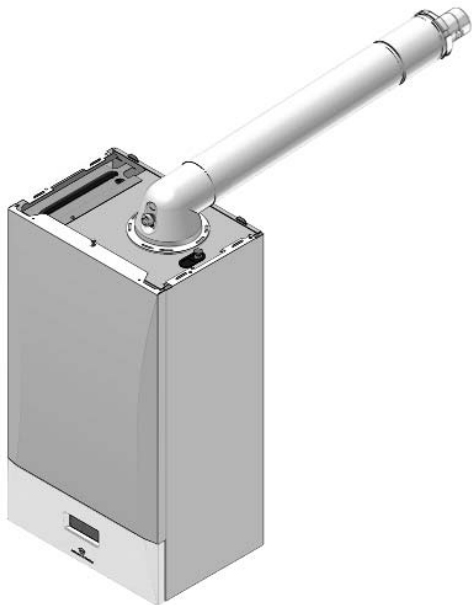

Fig. 3-7
Horizontal Rear Flue
(Standard Flue Kit)

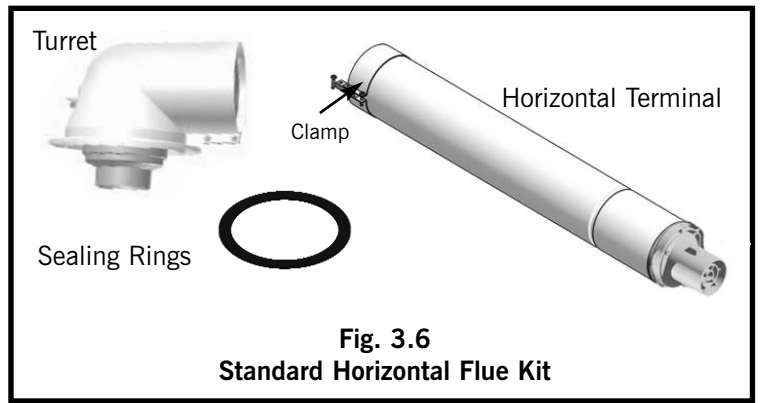

Fig. 3.6
Standard Horizontal Flue Kit

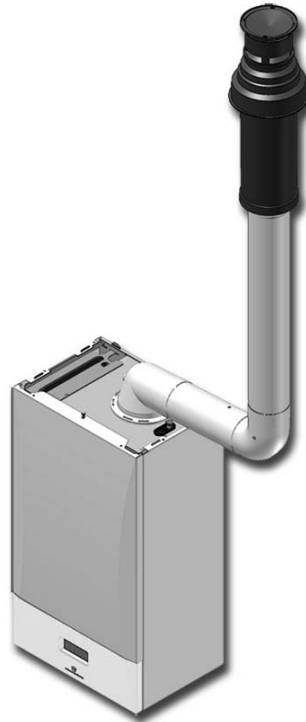

Fig. 3.8
Vertical Flue
(may be offset to the rear, left or right)

Turret
500 mm Extension
90° Elbow
Vertical Terminal

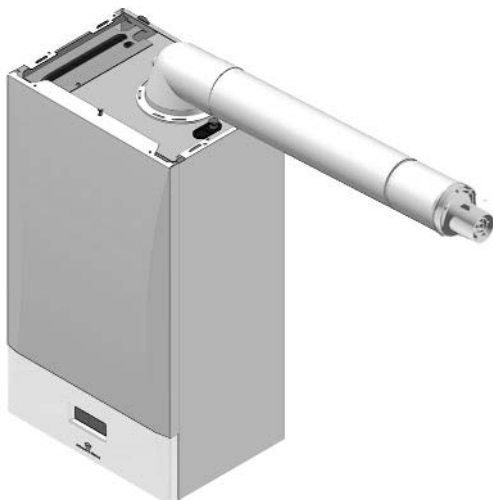

Fig. 3.9
Horizontal Side Flue
(Can be left or right)

Standard Flue Kit
500 mm Extension

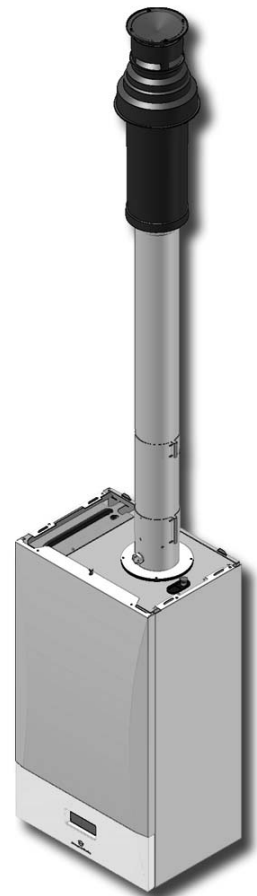

Fig. 3-10
Vertical Flue

1m Extension
500 mm Extension
Vertical Appliance Adaptor
Vertical Terminal

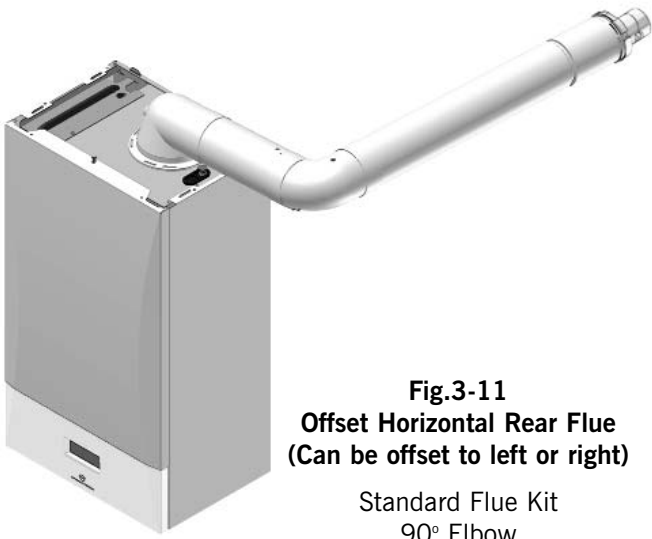

Fig.3-11
Offset Horizontal Rear Flue
 (Can be offset to left or right)

Standard Flue Kit
 90° Elbow
 1m Extension



Fig.3-12
Raised Horizontal Flue
 (Can also be LH or RH)

Horizontal Terminal
 90° Elbow
 1m Extension
 Vertical Appliance Adaptor

Typical Twin to Concentric Flue Configurations



Fig.3-13
Offset Twin to Vertical Concentric Terminal

Twin pipe adaptor
 80mm x 500mm extensions (2 off)
 80mm x 45° elbows (4 off)
 80mm x 1000mm extension (2 off)
 Twin to concentric adaptor
 60/100mm vertical terminal



Fig.3-14
Offset Twin to Horizontal Concentric Terminal

Twin pipe adaptor
 80mm x 500mm extensions (4 off)
 80mm x 90° elbows (2 off)
 Twin to concentric adaptor
 60/100mm horizontal terminal

Table.3-3

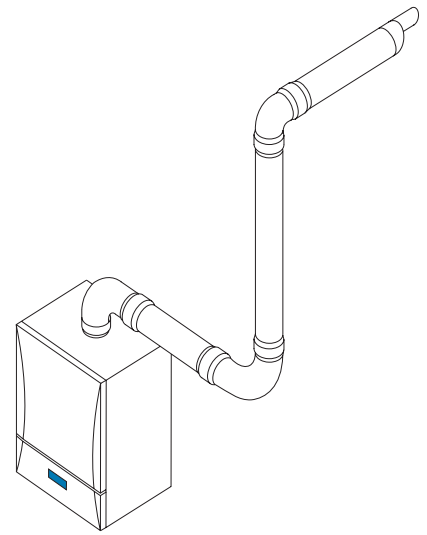
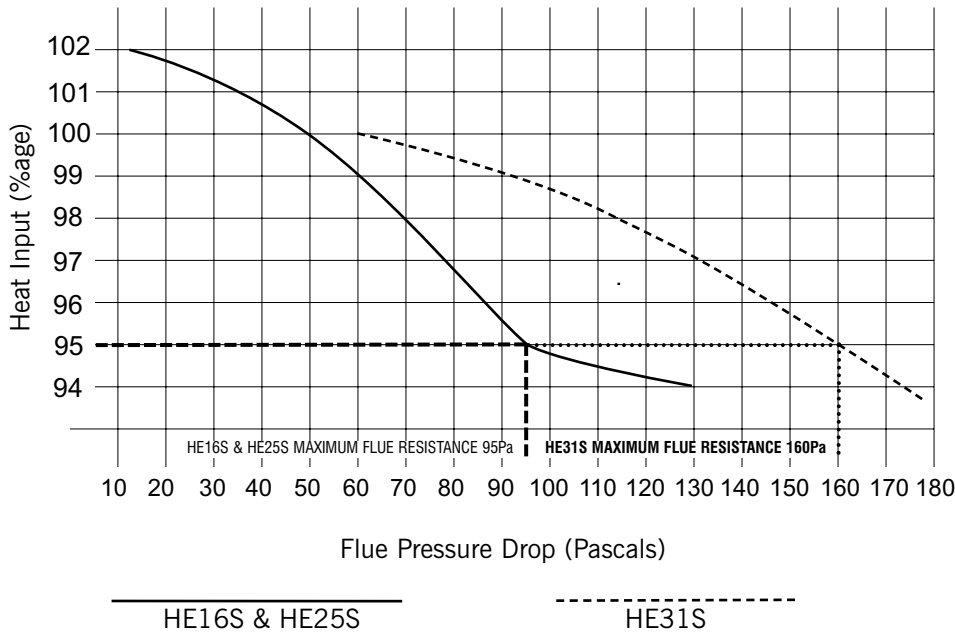

PRESSURE DROP EXAMPLE

Turret + Horizontal Terminal	= 45 Pa
500mm Extension	= 2.5 Pa
90 Elbow	= 10 Pa
100m Extension	= 5 Pa
90 Elbow	= 10 Pa
TOTAL	= 72.5 Pa

Description	Parts included	Application	Pt No	Pascal	
				30C	37C
Std flue kit (horizontal terminal)	1 x Turret.	Horizontal	1000-0020070	45	60
	1 x Appliance seal.				
	1 x 60/80 adaptor.				
	2 x EPDM wall cover plate.				
	1 x 100 mm diameter clamp.				
Turret	1 x Turret.	Horizontal	1000-0020020	40	45
Horizontal Terminal	1 x 800 mm horizontal terminal.	Horizontal	1000-0019830	5	15
1000 mm straight extension	1 x 1000 mm straight extension.	Horizontal Vertical	1000-0018940	5	15
	1 x 100 mm diameter clamp.				
	2 x screws.				
500 mm straight extension	1 x 500 mm straight extension.	Horizontal Vertical	1000-0018950	2.5	7.5
	1 x 100 mm diameter clamp.				
	2 x screws.				
250 mm straight extension	1 x 250 mm straight extension.	Horizontal Vertical	1000-0018960	1.25	4
	1 x 100 mm diameter clamp.				
	2 x screws.				
Vertical terminal 1140 mm	1 x vertical terminal assembly.	Vertical	1000-0018930	5	10
	1 x support bracket				
Vertical Appliance Adaptor	1 x Adaptor	Vertical	1000-0018990	0	0
90° elbow	1 x Elbow	Horizontal Vertical	1000-0018980	10	25
45° elbow	1 x Elbow	Horizontal Vertical	1000-0018970	5	12.5
Flat Roof Weather Collar	1 x Aluminium circular flat roof seal	Vertical	1000-0020060	N/A	N/A
Pitched Roof Collar (Black)	1 x Plastic & lead pitched roof seal	Vertical	1000-0020030	N/A	N/A
Pitched Roof Collar (Terracotta)	1 x Plastic & lead pitched roof seal	Vertical	1000-0020040	N/A	N/A
Fixing Bracket	Clamp for 100 mm tube	Horizontal	1000-0020050	N/A	N/A
		Vertical			

Table.3-5

60/100 Flue Components

3.10 Electrical Connections:

External wiring must be correctly earthed, polarised and in accordance with BS 7671 (current edition).

All system components must be an approved type and all electrical components should have been tested and meet the requirements of BEAB or equivalent. All the electrical connections to the heating system must be through a common double pole isolation switched spur that has a 3 mm separation on each pole and has a 3A rated fuse. It should be used for the heating system only and no other household components. A fused three pin plug and shuttered outlet may also be used provided they both comply with BS 1363.

Important. This appliance must be earthed and it must be wired in accordance with these instructions. In addition, it must have a permanent electrical supply that is not interrupted by a timing device or thermostat.

Fit the electrical supply cable as shown using the connection plug provided. The cable must be at least 0.75 mm², PVC insulated to BS 6500 table 16.

If a frost 'stat is required to protect remote parts of the heating system, this should be fitted as shown.

All cables entering/leaving the appliance MUST be restrained by use of the cable clamps.

An external controller can be fitted, in which case reference should be made to the appropriate diagram.

Optional System Controls: Opentherm protocol controls are available for outside temperature compensation and room temperature sensing and can be used to improve the heating system control. They must be connected to the correct terminals as described in their own instructions. A room thermostat MUST NOT be used with these controls.

3.11 Fitting The Case & Control Module:

Remove the case components from their packaging. Fit the LH and RH case panels to the appliance. Each panel hooks over the two lugs at the top of the appliance and screws to the base with the screws provided. Remove the controls door and offer the control module up to the side panels. The two hinge pins drop into the two slots on the goupset support. Fit the support strap (green cord) to the appliance LH side to support the controls in the horizontal position. Make the electrical harness connections to the rear of the module, ensuring that the harness connections are paired with their respective mates on the control module: X1; X2 etc. Swing the controls up into their vertical position and secure to the side case with the two screws provided. Refit the controls door and fit the front outer case and secure with the screw in the top of the boiler.

3.12 Electrical Testing:

Carry out electrical checks:

- Earth continuity and short circuit of cables
- Polarity of the mains supply
- Insulation resistance to earth

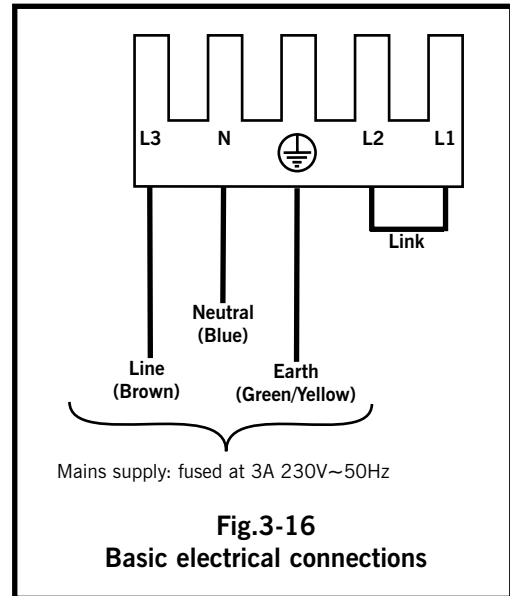

Fig.3-16
Basic electrical connections

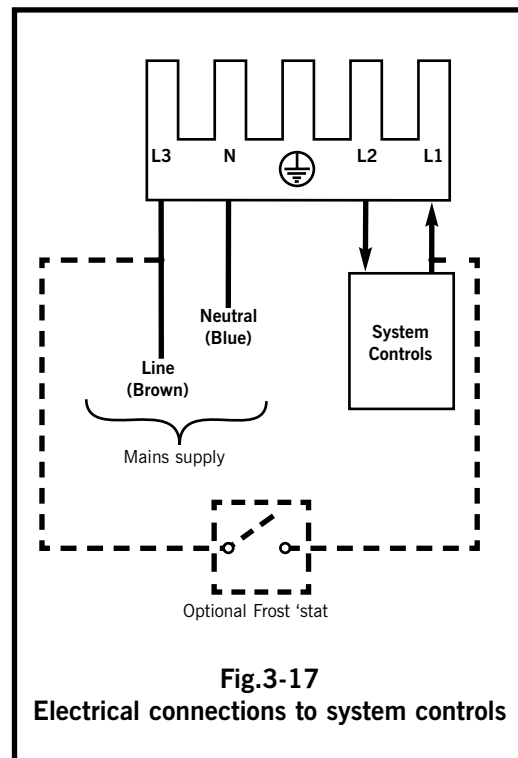

Fig.3-17
Electrical connections to system controls

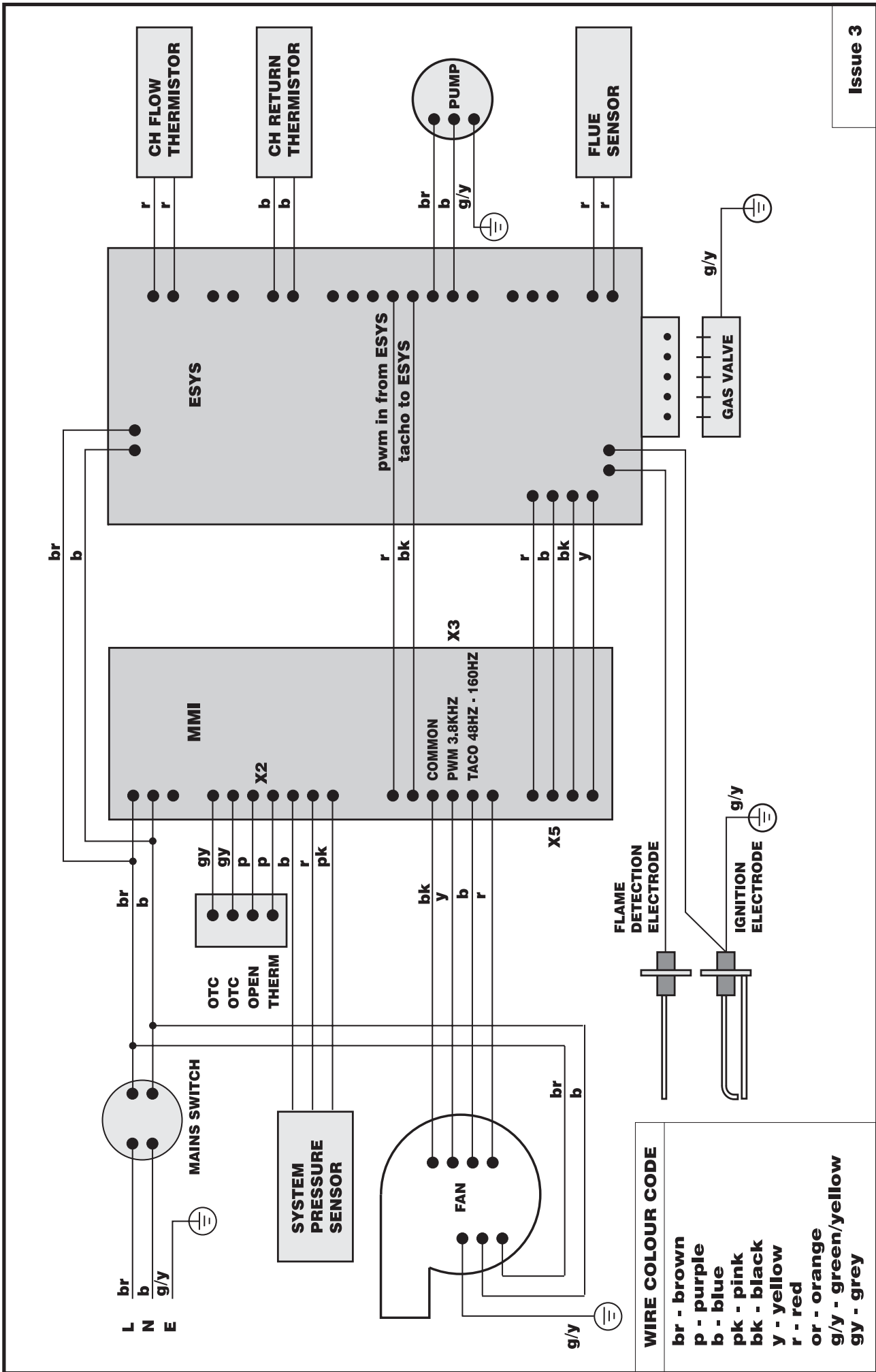
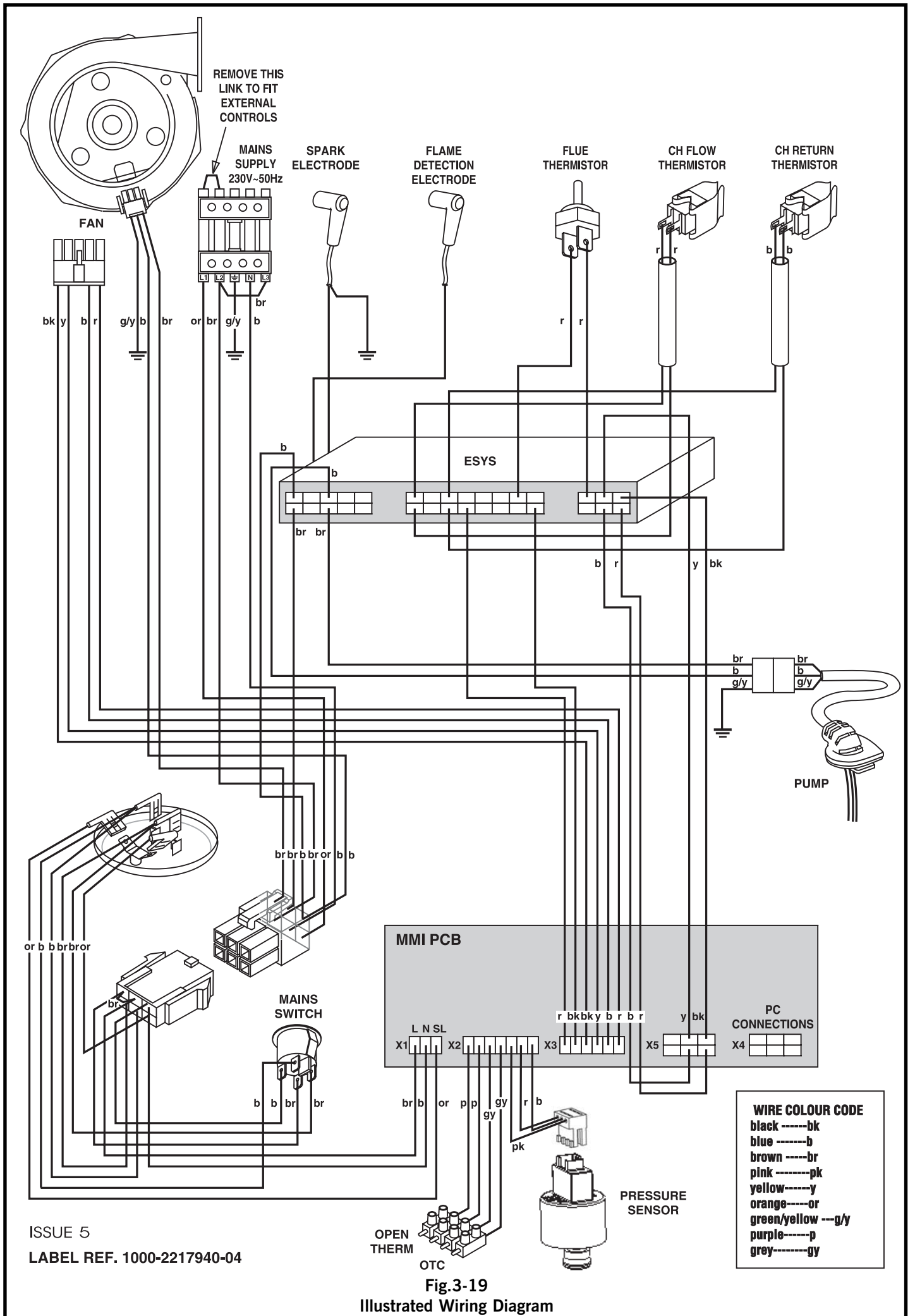

Fig.3-18
Functional Flow Diagram



WIRE COLOUR CODE

black	-----	bk
blue	-----	b
brown	-----	br
pink	-----	pk
yellow	-----	y
orange	-----	or
green/yellow	---	g/y
purple	-----	p
grey	-----	gy

4 COMMISSIONING AND HANDOVER

4.1 Commissioning the Appliance:

With all the pipe connections made, open the cold supply water valve on the filling loop and the CH flow and return valves at the base of the appliance. Open the manual vent at the top of the appliance and bleed, close the manual vent when all the air is removed.

Ensure that all isolating valves are open and that the system is pressurised to the correct level.

Having tested for gas tightness, purge air from the gas supply and turn on the gas service cock.

Ensure the domestic cold water system, all system radiators and the boiler, have been bled using the manual vent at the top of the appliance.

Turn the CH and DHW. controls to minimum, switch on the electricity supply to the appliance and turn ON the ON/OFF switch on the boiler control panel.

NOTE

The gas valve is factory preset and must not be adjusted. A replacement valve must only be supplied by Johnson & Starley Ltd.

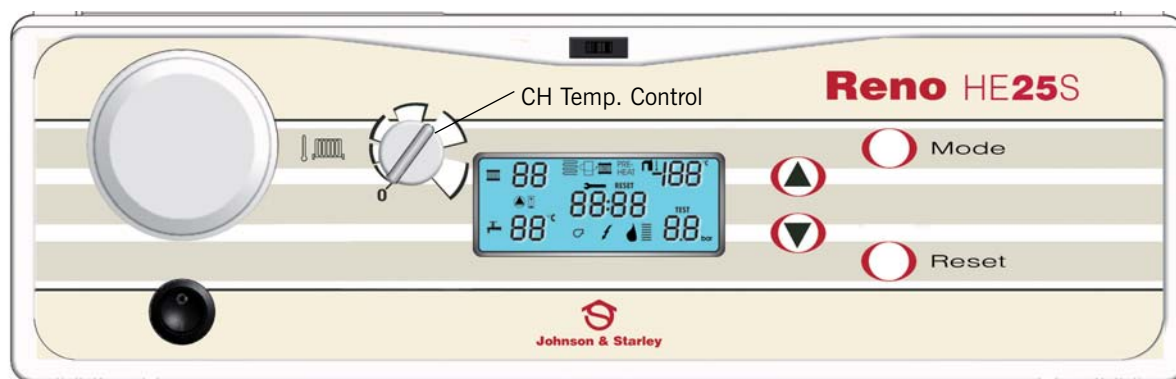

The LCD display will become active, whilst the microprocessor control completes a number of checks and sets the appliance to a standby position. When the boiler reaches its temp. set point, the anti-cycle feature introduces a 180 second delay between cycles, indicated by an hour glass symbol on the display. The display will indicate the system pressure in the lower RH corner of the LCD panel and a numerical display in the upper and lower LH side of the LCD panel.

Check that any external controls are calling for heat, and turn the CH temperature control clockwise. The set point temperature will be displayed on the LCD screen, set it to 60°. The fan will start and the ignition sequence will take place. The display will indicate the burner is on as well as an indication of fan speed. A stylised flame will be displayed when the flame is established.

If ignition does not take place during the first ignition attempt, there will be a further 2 attempts. If the burner has still not lit, a fault code will be displayed and this may be due to air being present in the gas supply. Pressing the reset button will initiate a second sequence of ignition attempts.

When the boiler lights, allow the appliance to operate at low temperature and vent all the air from the boiler and system. If necessary, re-pressurise the system to between 1.1 and 1.5 bar.

Turn OFF the appliance by turning the Central Heating Temp. Control to the OFF position.

When the above checks have been completed, a combustion performance test (as detailed in the SERVICING section) can be carried out if required.

4.2 Handing over:

After completion of the commissioning procedure, the installer should hand the appliance over to the occupier of the house by the following procedure:

- Hand the User Instructions (ZZ1187) to the occupier and explain their responsibilities in respect of current legislation and regulations, both national and local.
- Explain and demonstrate how to light and shut down the appliance.
- In order to gain the best possible fuel economy in relation to the heating and hot water requirements of the household, carefully explain the operation of the appliance and the use/adjustment of all the system controls.
- Advise on the precautions required to prevent damage to the appliance; the system and the building in the event of the appliance being shut down in very cold weather.
- Explain how to control the temperature of the radiators by use of the controls on the appliance.
- Explain how, in the event of a fault, the appliance will display a fault code, emphasising that if a fault is indicated they should note the fault code, turn off the appliance and contact a “competent person” which in normal circumstances would be a Gas Safe registered engineer.

- Explain and demonstrate the function/operation of time/temperature controls and thermostatic radiator valves, emphasising the economic use of the appliance.
- If a programmer has been fitted, hand the user instructions that were supplied with the programmer to the occupier.
- Point out the water pressure gauge and explain what it indicates and that if the pressure falls over a period of time when the system is cold, a water leak should be suspected and that a “competent person” should be contacted.
- Emphasise the importance of a regular service and that servicing of the appliance MUST only be carried out by a “competent person” which in normal circumstances would be a Gas Safe registered engineer.
- As the installer you may wish to offer a service contract yourself, or alternatively you may wish to explain to the occupier that they can take advantage of an extended warranty scheme offered by Johnson & Starley Ltd.

Reminder: At the time of commissioning, complete all relevant sections of the Benchmark Checklist located on the inside back pages of this document prior to handing over the appliance to the occupier.

5. SERVICING SCHEDULE

To ensure that the appliance gives continued operation that is both safe and efficient, it is necessary to carry out regular service checks and whilst the period between servicing will depend on the installation condition and the demands placed upon the appliance, it is recommended that the appliance be serviced annually.

NOTE: it is a statutory requirement that ALL work be carried out by a “competent person” which in normal circumstances would be a gas safe registered engineer.

5.1 Servicing Sequence:

- Light the boiler and carry out a pre-service check, noting any operational faults.
- Check the gas consumption.
- Put the appliance in test mode and connect a suitable flue gas analyser to the sampling point on the top of the boiler or into the flue terminal if access is possible (optional test).
For correct boiler operation, the ratio of CO to CO₂ in the flue gas should not be greater than 0.008.
Check that the gas input is at least 90% of the nominal. * See test mode inputs.
- Clean the main burner.
- Clean the heat exchanger.
- Check the condition of the combustion chamber insulation. Any cracked or damaged pieces should be replaced.
- Wherever possible, remove and clean the condensate 'S' trap (refer to section 6.12) and check the drain for blockage.
- Check that the flue terminal is unobstructed and that the flue system is sealed correctly.

Note. In order to carry out either servicing or replacement of components the boiler front panel and sealing panel must be removed. (Refer to section 6.2)

WARNING. Always turn OFF the gas supply at the gas service cock and switch OFF and disconnect the electricity supply to the appliance before servicing.

- After completing the servicing or exchange of components always test for gas tightness and carry out functional checks as described above.
- When work is complete, the sealing panel MUST be correctly refitted, ensuring that a good seal is made.
- If, for any reason, the condensate 'S' trap has been removed ensure the trap is refilled with water before reassembling.
- **After servicing, complete the relevant Service Interval Record section of the Benchmark Checklist located on the inside back pages of this document.**

Test Mode

To put the appliance in test mode, first press ▼ and whilst holding it, press the MODE button and hold both together until the display changes. (Possible 5 second time delay.) If the display shows *E H I 5* press RESET. and try again. The flow and return temperatures are displayed along with the flame current value and the fan speed. Whilst in test mode, the appliance overrides all temperature setting and defaults to maximum rate. Pressing the ▲ and ▼ buttons allows you to scroll between maximum and minimum rates, whilst still overriding all temperature settings*. Press RESET to take the appliance out of test mode. If no changes are made, the appliance will stay in test mode for 30 minutes.

When in max test mode the unit will run at 100% fan speed. This will give an input of -

			16S	25S	31S
INPUT	NET	Kw	16.3	30.6	38.0
	GROSS	Kw	18.1	34.0	42.1

* On smaller heating systems, running at maximum output MIGHT cause the boiler to go into lockout and display E3. Allow the heating system to cool and press RESET.

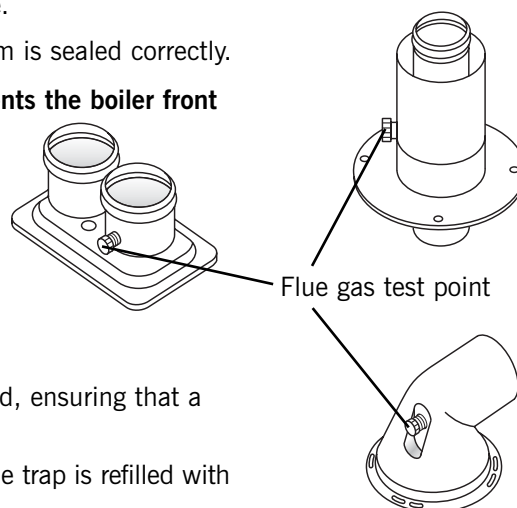

5.2 Gas/Air Duct and Internal Volume of the Burner

Remove the cover from the gas / air manifold (8 screws) and inspect the inside of the duct and burner for debris. Clean with a soft brush if necessary. Inspect the 'O' ring seal. Re-assemble the cover ensuring the seal is fitted correctly.

Gas/Air Duct

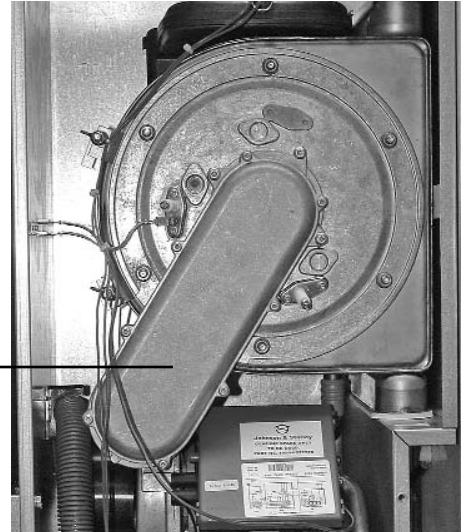

5.3 Combustion Assembly Complete

Remove the CVBC (refer to S6.16) and disconnect the gas pipe at the top of the isolation valve, which will already have been turned off. Unscrew the six retaining nuts from the studs that hold the assembly to the heat exchanger, supporting the assembly as the last one (bottom) is removed and slowly withdraw the complete assembly, including the gas inlet pipe and the case seal. As the assembly is withdrawn, disconnect the two electrical connections from the fan. Inspect and clean the spark ignition and flame sensing electrode, removing any debris and oxidization and check the spark gap and position of the spark electrode and the position of the flame-sensing electrode. Refer to the illustration and adjust if necessary. Inspect the two seals and the ceramic pad on the inside of the mounting plate and clean or replace as necessary.

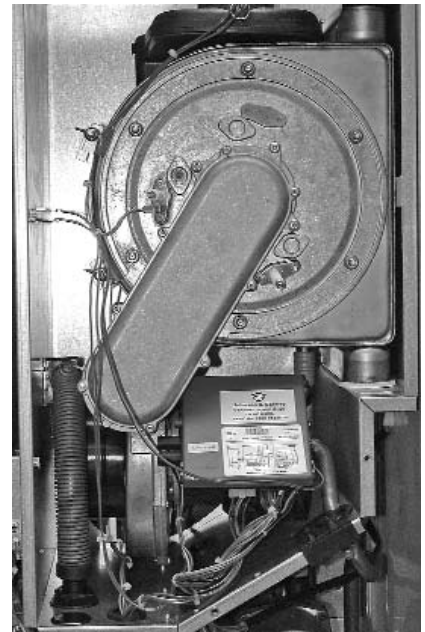

5.4 Combustion Chamber/Heat Exchanger

Inspect the inside of the combustion chamber for debris. If necessary, brush clean the inside of the tubes with a soft brush. Do not brush the insulation at the rear, if this part is damaged it will require replacement.



5.5 Ignition and Detection Electrodes

Remove the plug cap from the top and the earth wire from the base of the spark electrode. Unscrew the two screws that retain the electrode in the cover plate and remove the assembly. Inspect and clean the electrode, removing any debris and oxidation. If necessary use an abrasive paper or cloth. Inspect the gasket and replace if necessary during re-assembly. Repeat the sequence for the flame detection electrode with the exception of the earth lead.

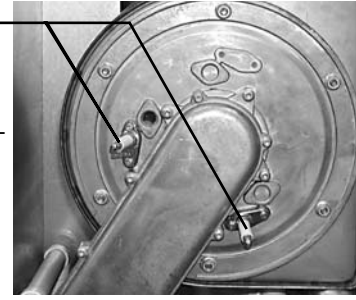

5.6 Condensate Cap (Where a siphon is fitted)

On some boilers an integral condensate siphon may have been fitted. This has a removable cap that allows the removal of debris that may be caught within it. Place a bowl under the cap to catch the condensate that is expelled and remove the cap. Any debris inside will be expelled at this point. Replace the cap ensuring a good seal is made. Discard the condensate and debris

Note: The condensate is a weak acid with a ph value of between 4 and 6.

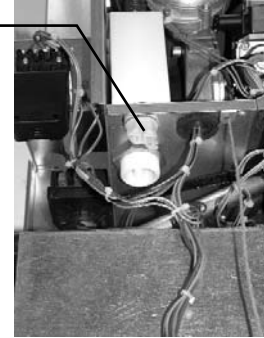

6. FAULT FINDING AND REPAIR

CAUTION:

Before commencing any mechanical servicing the appliance should be isolated from the electrical supply and the gas service cock on the appliance closed. All parts that are removed during a service operation should be replaced in reverse order, ensuring correct seals are made and wires are connected correctly. During the service remove any debris from within the appliance. When gas-carrying components are serviced the appliance must be tested for gas tightness after re-assembly. On completion of a service carry out a full functional test of all appliance components and ensure system controls are operating correctly.

Remove the upper front case that is retained by a screw in the top of the appliance.

Remove the control fascia by removing the plastic door, unscrewing the two screws that hold the control pod in place, rotate downward. Unplug the wires, slide the hinge pins inwards and remove the fascia from the appliance.

Remove the sealed door by removing the two screws and lifting the door clear.

Should a fault occur the boiler will shut down and the letter E followed by a two digit error code will be displayed.

ATTENTION:

The flip door at the bottom of the boiler is held in the closed position. To gain access to the control panel, take hold of the side of the panel at the corners and pull towards you, allowing the door to drop into the open position. To close the flip door, lift up the panel and push shut until it clicks into place.

6.1 Fault Codes

Code	Fault	Reason	Action
N/A	Boiler will not run	No call for heat to boiler control board	Check all external controls (if fitted) Check settings on time clock Check settings of boiler controls
1	Flame lockout after several attempts	Flame not detected	Check gas supply and gas cock If burner lights, check flame sensor and wiring to control board Check operation of gas valve
2	False flame	False flame sensed	Check wiring on ESYS
3	High water temp limit	Air in boiler No water	Vent boiler Check automatic bypass setting Check that flow temp sensor is clipped to flow pipe Check pump Check secondary heat exchanger for blockage
5	No tacho from fan	Fan not running or wiring fault	Check that fan runs Check wiring between MMI X7 and fan
8	Flame circuit error	Flame sensing lead shorted to earth.	Check flame detection lead between sensing probe and ignition control board.
9	Valve driver circuit error	Gas valve not detected	Check that ESYS is correctly fitted on gas valve Replace ignition control board or gas valve
11	Flow/return sensor calibration error	Flow/return sensors not within 5° of each other, within calibration period.	Check that there is a bypass in the system Check that the flow/return sensors are fitted to the pipes
12	Default lockout	Eprom memory fault	Change ESYS
13	Elapsed the number of retrials		Change ESYS
21	ADC error		Change ESYS
26	Flame signal lost 5 times in 4 minutes	Flame sensing error. Falling gas pressure. Fan fault. Flue blockage.	Check flame detection lead between sensor and ignition control board. Check gas supply does pressure fall when boiler fires? Check that flue system is not blocked.
31	CH supply sensor error (open or short)	Sensor out of normal range.	Check wiring and connections Check sensor continuity
44	CH rreturn sensor error (open or short)	Sensor out of normal range. Temperature sensor not connected or failed	Check wiring and connections Check sensor continuity
BLOCKING ERRORS			
7	High flue gas temp	Reduced water flow	Check insulation at back of heat exchanger for damage Check water content and pump operation.
25	CRC error	Error between Hup and Lup CRC codes	Check software versions
30	Boiler flow temperature sensor short circuit	Temperature sensor shorted to earth or failed.	Check wiring and connections for shorting to earth Check sensor resistance
31	Boiler flow temperature sensor open circuit	Temperature sensor not connected or failed	Check wiring and connections. Check sensor continuity
34	Low mains supply voltage	Electrical supply fault to property. Faulty wiring to appliance	Check incoming mains supply and wiring to appliance
37	Low system water pressure	Water pressure low or sensor failed.	Check system pressure on dial gauge and if correct check pressure sensor and wiring. Re pressurise system.
40	High system water pressure	System water pressure too high. Pressure sensor failed.	Check cold system pressure. Check expansion tank charge pressure with system pressure released. Check pressure sensor
41	No water pressure signal recieved from MMI	The water pressure is not refreshed often enough. Communication problem.	Check wiring and connections
45	Flue gas temperature sensor short circuit	Short circuit in wiring between sensor and control board	Check wiring to sensor Check the electrical resistance of the sensor
46	Flue gas temperature sensor open circuit	Temperature sensor not connected or failed	Check wiring and connections. Check sensor continuity
47	Water pressure sensor open circuit	Water pressure sensor not connected	Check wiring and connections. Check sensor continuity
99	Communication MMI-ESYS lost	Connection between MMI & ESYS incor-rectly made	Check wiring and connections

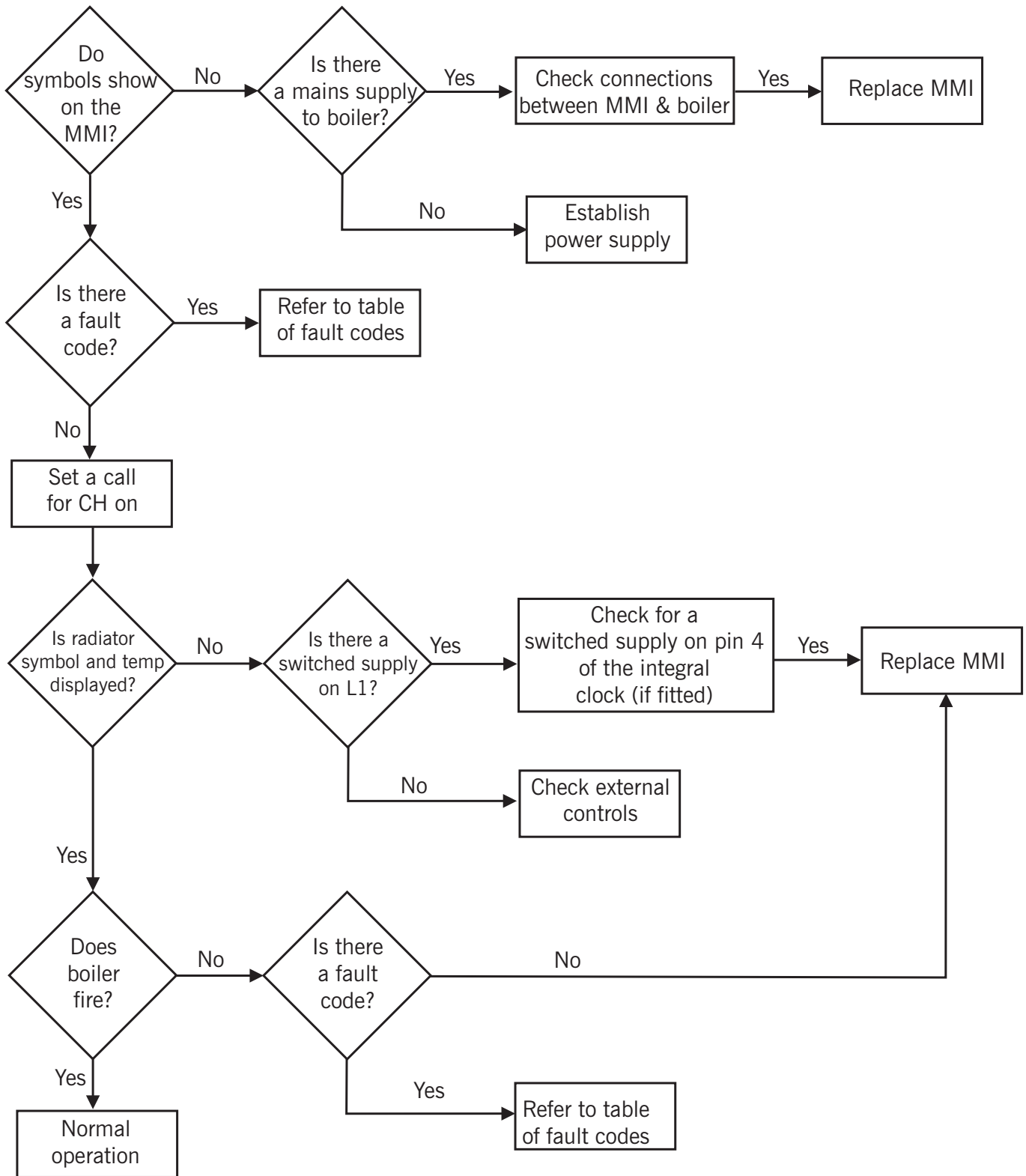

Error History Mode

The MMI stores the last 8 error codes and these can be viewed by putting the appliance into error history mode.

To do this, press the **MODE** button and "EHIS" will be displayed on the LCD display. The number in the top right hand-corner is the error index (1 being the most recent) and the number in the bottom right hand corner is the error code that applies to that index number.

The appliance will stay in error history mode for a period of 30 seconds and pressing the ▼ and ▲ buttons allows you to scroll through the error codes stored.

Press RESET to manually take the appliance out of error history mode.



NOTE: all new boilers are shipped with pre-set error codes stored in the memory.

Replacement of Parts

6.2 Initial Disassembly

Remove the upper front case that is retained by a screw in the top of the appliance.

Remove the control fascia by removing the plastic door, unscrewing the two screws that hold the control module in place, rotate downward. Unplug the wires, slide the hinge pins inwards and remove the fascia from the appliance.

Remove the sealed door by removing the two screws and easing it to the left to disengage it from the LH side of internal casing.

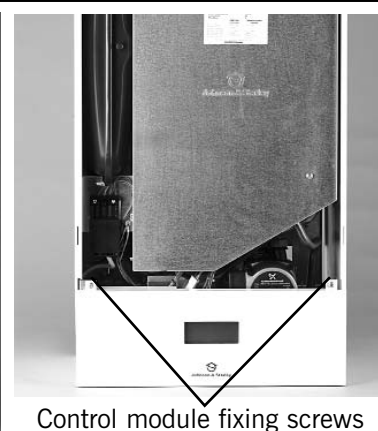

6.3 Control Panel (complete)

Because of the complexity and delicate nature of the control PCB, it is supplied as a complete kit with the plastic fascia.

Remove the control panel as described at section 6.2. and fit the new assembly in reverse order.

6.4 Electrical Switch

Unscrew the metal cover plate from the rear of the control panel. Unplug the wires from the switch (NOTING THEIR POSITIONS) and remove the switch. Fit the the new switch and reconnect the wires ensuring that they are in the correct position.

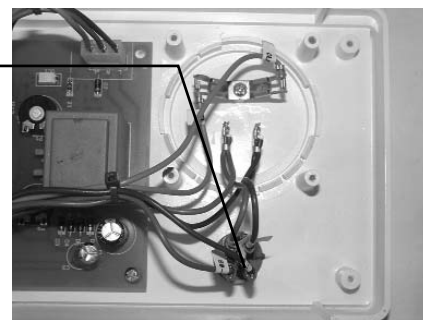

6.5 Pump (Complete)

Close the CH flow and return valves, ensuring the drain point on the flow valve is connected to the appliance side. Drain off the water from within the appliance using the drain valve. Unplug the electrical connector from the flying lead and unscrew the lower screw that retains the pump to the appliance. Withdraw the retaining clip securing the flexible expansion pipe and pull the pipe from the pump. Withdraw the retaining clip at the rear of the body and remove the pump complete. Replace with a new component in reverse order.

6.7 Expansion Vessel

Close the CH flow and return valves, ensuring the drain point on the flow valve is connected to the appliance side. Drain off the water from within the appliance using the drain valve, remove the LH painted case side and unscrew the flexible hose connection from the expansion vessel. Unscrew the upper retaining bracket and remove the expansion vessel. Replace with a new component in reverse order.

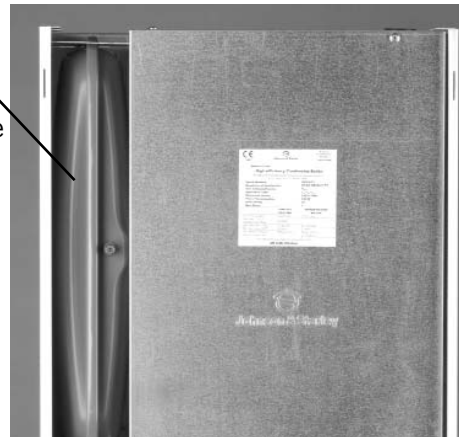

6.8 Pressure Relief Valve

Close the CH flow and return valves, ensuring the drain point on the flow valve is connected to the appliance side. Drain off the water from within the appliance using the drain valve, remove the pump as described in section 6.5 and unscrew the discharge connection. Withdraw the retaining clip and remove the pressure relief valve. Replace with a new component in reverse order.



6.9 Primary Water Temperature Sensors (2 off)

Unplug the two wires from the temperature sensor to be replaced and unclip the sensor from the pipe. Replace with a new component in reverse order, ensuring it is fitted in the same position.

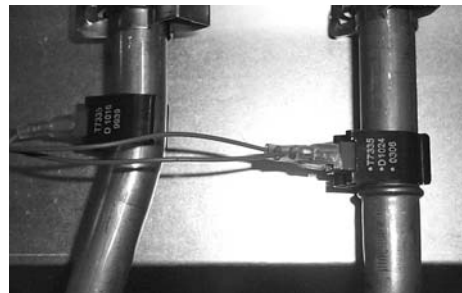

6.10 Primary Water Pressure Sensor

Close the CH flow and return valves, ensuring the drain point on the flow valve is connected to the appliance side. Drain off the water from within the appliance using the drain valve, unplug the electrical plug connection, withdraw the retaining clip forwards and remove the pressure sensor. Replace with a new component in reverse order.

6.11 Condensate Drain

Referring to s.5.3, remove the complete combustion assembly including the burner arm. The flexible condensate pipe is a push fit and the grey fitting connects to the heat exchanger. The flexible pipe MUST be routed through the two push fit retaining clips so that the pipe forms a "S" shaped trap. With the burner arm removed, pour water into the heat exchanger in order to fill the condensate drain pipe and check for leaks. Reassemble in reverse order.

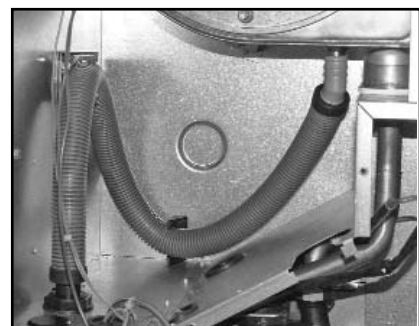

6.12 Condensate Siphon (Where Fitted)

Place a bowl under the cap on the condensate siphon and remove the cap in order to drain the siphon.

Pull the condense pipe from the top of the siphon and remove the fixing screw retaining the support bracket. Unscrew the knurled ring underneath the siphon and remove the drain pipe from the bottom of the siphon. Unscrew the 1" brass lock nut from the bottom of the siphon and remove the siphon from the sub assembly. Replace with a new component in reverse order.

Fixing screw

Knurled Ring

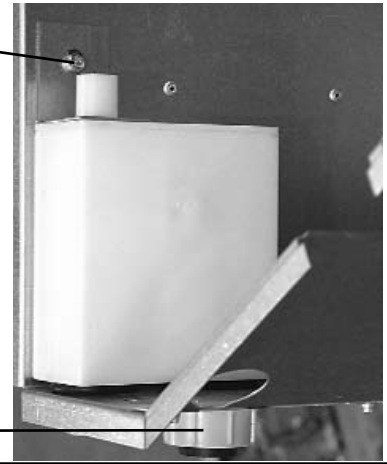

6.13 Ignition Electrode

Remove the plug cap and the earth wire from the electrode. Remove the two retaining screws and withdraw the electrode. Replace with a new unit, ensuring that the gasket is replaced with a new one, or that the existing gasket reused if it is in good condition.

6.14 Flame Detection Electrode

Remove the plug cap from the electrode. Remove the two retaining screws and withdraw the electrode. Replace with a new unit, ensuring the gasket is replaced with a new one, or the existing gasket reused if it is in good condition.

IMPORTANT:

When either the ignition or flame detection electrodes have been serviced/replaced you MUST set the clearances as shown.

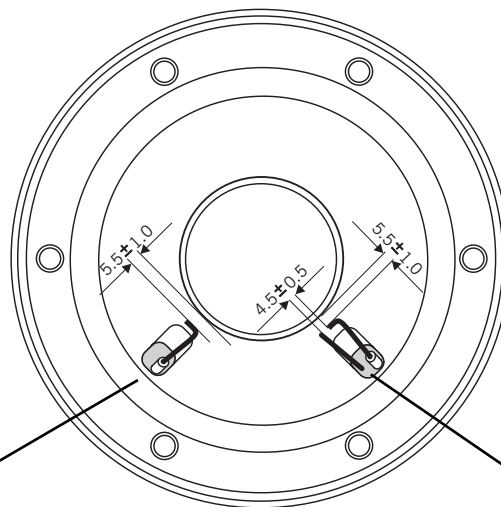

Flame Detection Electrode

Ignition Electrode

Clearances

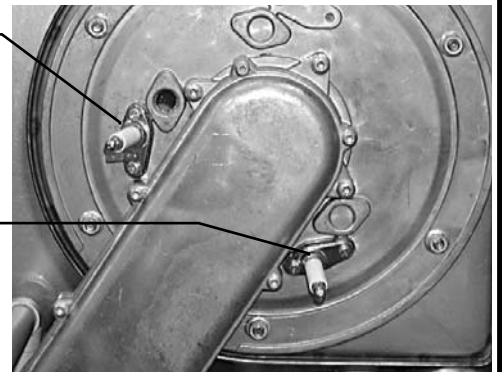

6.15 Burner

Unscrew the gas joint at the top of the gas cock. Unscrew the fan and gas/air manifold assembly (3 screws) from the heat exchanger. Unplug the multi pin plug connections from the top of the control and the fan. Remove the assembly.

Remove the assembly to allow the burner to be withdrawn from the heat exchanger assembly. Replace with a new component in reverse order. Ensure the rotational position of the burner is correct. Replace with a new component in reverse order ensuring that the grommet sealing the casing is correctly positioned.



6.16 Main Ignition/Control PCB (ESYS Grey/Red Housing on Gas Valve)

Unplug the multi pin plug connections from the top of the control and remove the spark detection wires. Unscrew the single retaining screw and slide the housing off the gas valve electrical connections. Replace with a new component in reverse order.

NOTE: The ESYS label is identified with the addition of an 'E' alongside the 3 stars.



6.17 Flue Temperature Sensor

Carefully pull the two spade connectors from the sensor and unscrew the sensor from the plastic flue hood. Replace with a new component in reverse order.



6.18 Fan

Unscrew the gas joint at the top of the gas cock and remove the ESYS (red box) from the gas valve. Unscrew the fan and gas/air manifold assembly (3 screws) from the heat exchanger. Unplug the multi pin plug connections from the top of the control and the fan. Remove the assembly. Replace with a new component in reverse order.



6.19 Gas Valve & Venturi Assembly

NOTE: the gas valve is factory preset and a must not be adjusted. A replacement valve must only be supplied by Johnson & Starley Ltd.

Remove the complete fan assembly as shown at section 6.18 and remove the 4 fixing screws holding the gas feed flange on the gas valve. Remove the 2 fixing screws securing the venturi (and gas valve) to the fan and remove the assembly from the fan carefully removing the gasket.

Replace with a new component in reverse order, ensuring that all seals are in good condition and correctly positioned. Check the gas rate and combustion as described in section 5 Servicing Instructions.

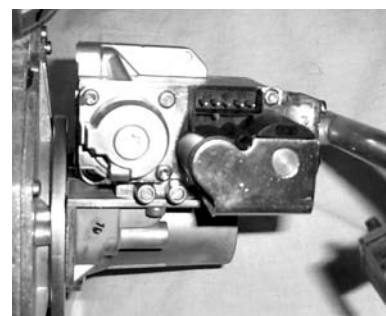

7 SHORT SPARE PARTS LIST

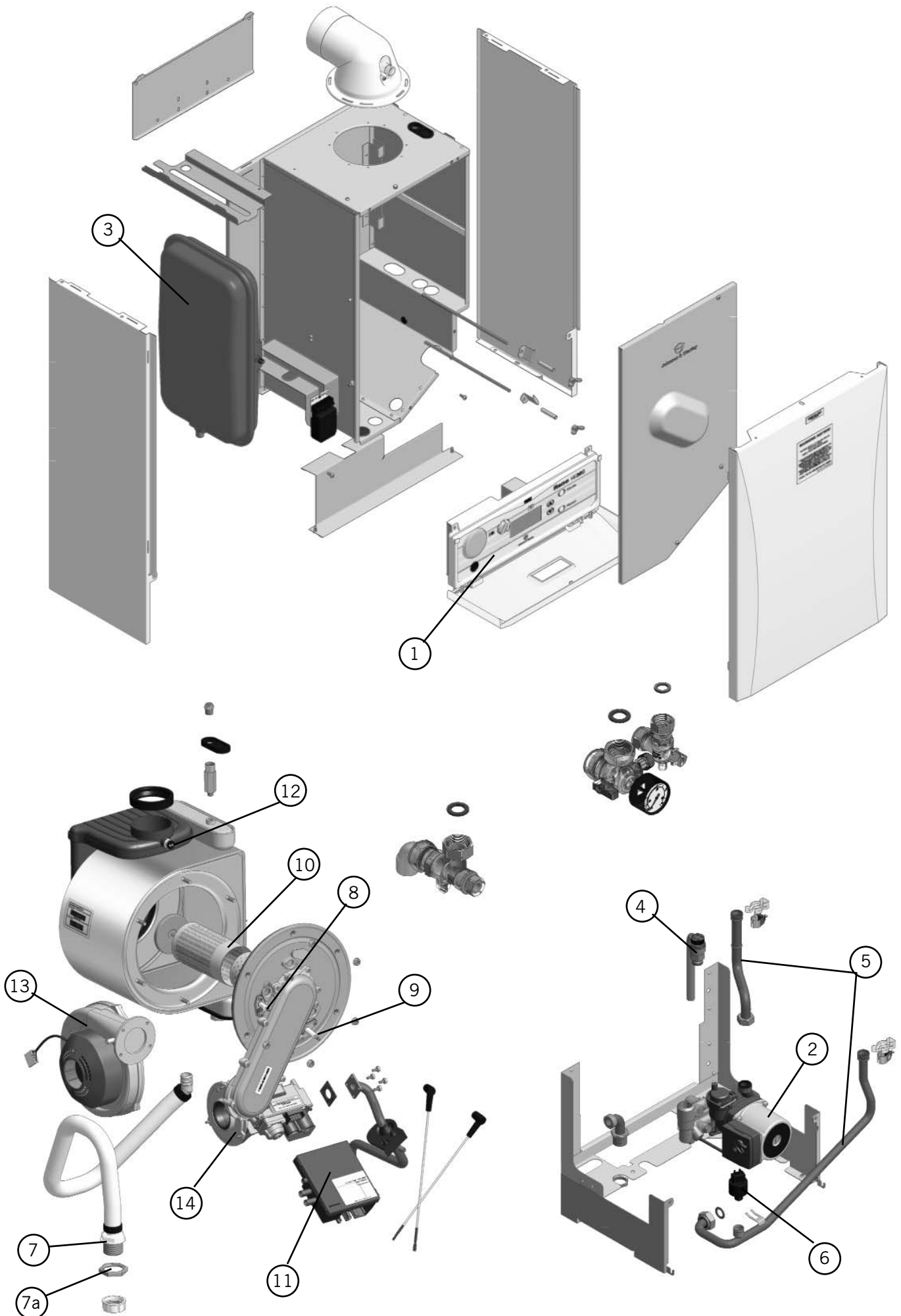

Item	Part No	GC No	Description
HE25S			
1	R300-0510005	H23-607	Control Panel (complete)
2	1000-0301485	H23-609	Pump
3	1000-0019005	H23-610	Expansion Vessel (with Washer)
4	1000-0019015	H23-612	Pressure Relief Valve
5	1000-0522595	H23-613	Water Temperature Sensors
6	1000-0019045	H23-614	CH Pressure Sensor, Clip & 'O' Ring
7	1000-0020895	H39-975	Tank Connector
7a	1000-0020905	H39-976	Tank Connector Nut
8	1000-0709655	H23-618	Ignition Electrode, Gasket & Screws (2)
9	1000-0709665	H23-619	Detection Electrode, Gasket & Screws (2)
10	1000-0709675	H23-620	Burner and Small Seal
11	1000-0522575	H23-621	Main Ignition/Control PCB (ESYS)
11	1000-0523395	H38-658	Main Ignition/Control PCB (ESYS) from serial No: 69000240
12	1000-0522645	H23-622	Flue Temp. Sensor
13	1000-0522635	H23-623	Fan, Gaskets (3) & Fixing Screws
14	1000-0709635	H23-624	Gas Valve & Venturi Assy (inc fan gasket, pipe gasket & screws (4))
HE31S (as HE25S with the following variations)			
1	R320-0510005	H39-973	Control Panel (complete)
10	1000-0709825	H39-967	Burner and Small Seal
11	1000-0523405	H39-970	Main Ignition/Control PCB (ESYS)
14	1000-0709875	H39-972	Gas Valve & Venturi Assy (inc fan gasket, pipe gasket & screws (4))
HE16S (as HE25S with the following variations)			
1	R160-0510005	H39-980	Control Panel (complete)
10	1000-0709805	H39-978	Burner and Small Seal
11	1000-0523415	H39-981	Main Ignition/Control PCB (ESYS)
14	1000-0709865	H39-995	Gas Valve & Venturi Assy (inc fan gasket, pipe gasket & screws (4))

GAS BOILER SYSTEM COMMISSIONING CHECKLIST

This Commissioning Checklist is to be completed in full by the competent person who commissioned the boiler as a means of demonstrating compliance with the appropriate Building Regulations and then handed to the customer to keep for future reference.

Failure to install and commission according to the manufacturer's instructions and complete this Benchmark Commissioning Checklist will invalidate the warranty. This does not affect the customer's statutory rights.

Customer Name _____ Telephone Number _____

Address _____

Boiler Make and Model _____

Boiler Serial Number _____

Commissioned by (Area name) _____ Gas Safe Register Number _____

Company Name _____ Telephone Number _____

Company Address _____

Commissioning Date _____

To be completed by the customer on receipt of a Building Regulations Compliance Certificate*:

Building Regulations Notification Number (if applicable) _____

CONTROLS Tick the appropriate boxes

Time and Temperature Control to Heating	Room Thermostat and Programme Timer	<input type="checkbox"/>	Programmable Room Thermostat	<input type="checkbox"/>	Load/Weather Compensation	<input type="checkbox"/>	Optimum Start Control	<input type="checkbox"/>
Time and Temperature Control to Hot Water	Cylinder Thermostat and Programme Timer			Combination Boiler				
Heating Zone Valves				Fitted	Not Fitted			
Hot Water Zone Valves				Fitted	Not Fitted			
The most radiator Valves				Fitted	Not Fitted			
Automatic Bypass to System				Fitted	Not Fitted			
Boiler Interlock				Provided				

ALL SYSTEMS

The system has been flushed and bled in accordance with BS7593 and boiler manufacturer's instructions Yes

What system cleaner was used? _____

What inhibitor was used? _____ Quantity litres

CENTRAL HEATING MODE Measure and Record:

Gas Rate	<input type="text"/>	m ³ /hr	OR	<input type="text"/>	hr/hw
burner Operating Pressure (if applicable)	<input type="text"/>	mbar	OR	Gas Inlet Pressure	<input type="text"/>
General Heating Flow Temperature					<input type="text"/>
General Heating Return Temperature					<input type="text"/>

COMBINATION BOILERS ONLY

Is the installation in a hard water area (above 200ppm)? Yes No

If yes, have scale reducers been fitted? Yes No

What type of scale reducer has been fitted? _____

DOMESTIC HOT WATER MODE Measure and Record:

Gas Rate	<input type="text"/>	m ³ /hr	OR	<input type="text"/>	hr/hw
burner Operating Pressure (if applicable)	<input type="text"/>	mbar	OR	Gas Inlet Pressure (if applicable)	<input type="text"/>
Cold Water Inlet Temperature					<input type="text"/>
Hot water has been checked at all outlets				Yes <input type="checkbox"/>	Is was done <input type="checkbox"/>
Water Flow Rate					<input type="text"/>

CONDENSING BOILERS ONLY

The condensate drain has been installed in accordance with the manufacturer's instructions and/or BS6644/BS6736 Yes

ALL INSTALLATIONS

If required by the manufacturer, record the following CO₂ % OR CO ppm OR CO/CO₂ Ratio

The heating and hot water system complies with the appropriate Building Regulations Yes

The boiler and associated products have been installed and commissioned in accordance with the manufacturer's instructions Yes

The operation of the boiler and system controls has been demonstrated to and understood by the customer Yes

The manufacturer's literature, including Benchmark Checklist and Service Record, has been explained and left with the customer Yes

Commissioning Engineer's Signature _____

Customer's Signature _____

(to be completed by the customer on receipt of a Building Regulations Compliance Certificate)

*All installations in England and Wales must be covered by local Authority building control. Details can be checked through a Competent Person Scheme or a Building Regulations Compliance Certificate. These should be handed to the customer.



Service Record

It is recommended that your heating system is serviced regularly and that the appropriate Service Interval Record is completed.

Service Provider

Before completing the appropriate Service Interval Record below, please ensure you have carried out the service as described in the manufacturer's instructions.

Always use the manufacturer's specified spare part when replacing controls.

Service 1

Date: _____

Engineer Name: _____

Company Name: _____

Telephone No. _____

Operative ID No. _____

Comments: _____

Signature: _____

Service 2

Date: _____

Engineer Name: _____

Company Name: _____

Telephone No. _____

Operative ID No. _____

Comments: _____

Signature: _____

Service 3

Date: _____

Engineer Name: _____

Company Name: _____

Telephone No. _____

Operative ID No. _____

Comments: _____

Signature: _____

Service 4

Date: _____

Engineer Name: _____

Company Name: _____

Telephone No. _____

Operative ID No. _____

Comments: _____

Signature: _____

Service 5

Date: _____

Engineer Name: _____

Company Name: _____

Telephone No. _____

Operative ID No. _____

Comments: _____

Signature: _____

Service 6

Date: _____

Engineer Name: _____

Company Name: _____

Telephone No. _____

Operative ID No. _____

Comments: _____

Signature: _____

Service 7

Date: _____

Engineer Name: _____

Company Name: _____

Telephone No. _____

Operative ID No. _____

Comments: _____

Signature: _____

Service 8

Date: _____

Engineer Name: _____

Company Name: _____

Telephone No. _____

Operative ID No. _____

Comments: _____

Signature: _____

Service 9

Date: _____

Engineer Name: _____

Company Name: _____

Telephone No. _____

Operative ID No. _____

Comments: _____

Signature: _____

Service 10

Date: _____

Engineer Name: _____

Company Name: _____

Telephone No. _____

Operative ID No. _____

Comments: _____

Signature: _____

Johnson & Starley are the leading UK & European manufacturers of a complete range of **Domestic Warm Air Heaters**. All the heaters suit both **Replacement** and **Upgrade** needs and are compliant with the new (2006) amendments to Part L of the Building Regulations.

HOME COMFORT SOLUTIONS

Company Details

Website Address	www.johnsonandstarley.co.uk
Email	sales@johnsonandstarley.co.uk marketing@johnsonandstarley.co.uk
Telephone Number	01604 762881 (Main switchboard)
Fax Number	01604 767408

Spares

Telephone	01604 707012
Fax	01604 762884

Sales

Telephone	01604 707012
Fax	01604 764879

Service

Telephone	01604 707011
Fax	01604 707017

Warm Air Upgrade Enquiry Service

Telephone	01604 707026
Fax	01604 707017



RENO BOILER RANGE



HI-SPEC BOILER RANGE



ECONOMAIRE BOILER RANGE



HOME 'N' DRY VENTILATION



DRYFLOW



HEAT RECOVERY

COMMERCIAL & INDUSTRIAL H&V SOLUTIONS

Company Details

Johnson & Starley Dravo Division Industrial H&V	
Website Address	www.dravo.co.uk
Email	dravo@johnsonandstarley.co.uk
Telephone Number	01604 707022
Fax Number	01604 706467



RELIABILITY YOU CAN TRUST

Rhosili Road, Brackmills, Northampton NN4 7LZ

In the interests of continuous development Johnson & Starley reserve the right to change specification without prior notice.